



3C产品综合手册

3C product comprehensive manual

—点胶设备·锁付设备·贴装设备—
—dispensing equipment, locking equipment and mounting equipment—

COMPANY PROFILE

企业介绍



东莞市纳声电子设备科技有限公司，成立于2008年，是专精特新国家级高新技术企业，集精密设备的研发、设计、生产、销售、服务为一体，总部座落于东莞松山湖，在珠三角、苏州、江西、重庆、越南等设立多个办事处，成立至今，已获得专利100多项软件注册权及软件权，以优质品质引领行业，是华为、富士康、立讯精密、苹果、ViVO、OPPO、小米、TCL通力、华勤、大疆、德赛、领益、联创等100多家国内外头部企业(相关)合作。

厂房面积12000平方米，员工200+人，其中技术人员150+人，研发人员60+人，精密CNC数控加工设备50+台，产品主要应用于3C电子、声学、航空航天、汽车电子、5G通讯、智能家居、新能源、LED、生物医疗、半导体封装轨道交通等行业。

Dongguan Nasheng Electronic Equipment Technology Co., Ltd., established in 2008, is a national high-tech enterprise specializing in precision, novelty, and novelty. It integrates the research and development, design, production, sales, and service of precision equipment. Its headquarters is located in Songshan Lake, Dongguan, and it has set up multiple offices in the Pearl River Delta, Suzhou, Jiangxi, Chongqing, Vietnam, and other areas. Since its establishment, it has obtained more than 100 software registration rights and software rights patents, leading the industry with high-quality products. It is Huawei, More than 100 domestic and foreign leading enterprises (related) have cooperated, including Foxconn, Lixun Precision, Apple, VIVO, OPPO, Xiaomi, TCL Tongli, Waller, DJI, Desai, Lingyi, and Lian chuang.

The factory covers an area of 12000 square meters and employs over 200 people, including 150 technical personnel and 60 research and development personnel. More than 50 precision CNC machining equipment are mainly used in industries such as 3C electronics, acoustics, aerospace, automotive electronics, 5G communication, smart home, new energy, LED, biomedicine, semiconductor packaging and rail transportation.



技术开发愿景

Technology development vision

我们一直坚持技术创新，持续的技术创新能力是企业可持续发展的源动力，积极着眼于当前及未来行业的发展趋势和客户的要求，开发和定制各种高品质的生产设备，同时，提供相关生产工艺流程的解决方案，最大限度地为客户创造价值！

We always insist on technological innovation, and the continuous technological innovation ability is the source power for the sustainable development of enterprises. We actively focus on the current and future industry development trends and customer requirements, develop and customize various high-quality production equipment, and at the same time, provide solutions for related production processes to create value for customers to the maximum extent!





SERVE CUSTOMERS DIRECTLY OR INDIRECTLY

直接或间接服务客户

鉴于客户保密协议，所展示为公司部分案例，排名不存在相关关联性

In view of the customer confidentiality agreement, some cases of the company are shown, and there is no correlation in the ranking.



- 01 落地式精密高速点胶机系列** P 01-23
Floor-standing precision high-speed dispensing series
- 02 全自动灌胶机系列** P 24-27
All automatic glue machine series
- 03 桌面式精密点胶机系列** P 28-37
Desktop precision dispensing machine series
- 04 核心胶控部品系列** P 38-63
Core rubber control parts series
- 05 LED UV灯固化设备系列** P 64-71
LED UV lamp curing equipment series
- 06 自动锁付螺丝机系列** P 72-87
Automatic locking screw machine series
- 07 自动柔性上料/贴合设备** P 88-89
Automatic flexible feeding/laminating equipment
- 08 自动微焊接机器人系列** P 90-101
Automatic micro-welding robot series



点胶适用流体范围 Applicable fluid range of dispensing

各种溶剂、粘接剂、油漆、化学材料、固体胶等，包括硅胶、EMI导电胶、UV胶、AB胶、快干胶、环氧胶、密封胶、热胶、润滑脂、银角、红胶、锡膏、散热胶、防焊胶、透明漆、螺丝固定剂，木工胶、厌氧胶、亚克力胶、防磨胶、水晶胶、灌注胶、喇叭胶、瞬间胶、橡胶、油漆、搪瓷漆、亮漆、油墨、颜料等。

Various solvents, adhesives, paints, chemical materials, glue stick, etc., including silica gel, EMI conductive adhesive, UV glue, AB glue, dry glue, epoxy glue, sealant, hot glue, grease, silver horn, red glue, solder paste, heat dissipation glue, solder mask, transparent paint, screw fixer, wood working glue, anaerobic glue, acrylic glue, anti-wear glue and crystal glue.

流体材料粘度表 Fluid material viscosity table



点胶量标准 Dispensing quantity standard

φ (mm)	0.1	0.25	0.5	0.75	1.0	1.5	2.0	3.0	4.0	5.0	6.0	7.0	8.0	9.0	10.0
(mg)															
水	0.00026	0.00409	0.033	0.110	0.262	0.884	2.094	7.069	16.76	32.72	56.55	89.80	134.0	190.9	261.8
UV粘合剂	0.00031	0.00491	0.039	0.133	0.314	1.060	2.513	8.482	20.11	39.27	67.86	107.76	160.8	229.0	314.2
银焊膏	0.00084	0.01309	0.105	0.353	0.838	2.827	6.702	22.619	53.62	104.72	180.96	287.35	428.9	610.7	837.8
焊膏	0.00223	0.03477	0.278	0.939	2.225	7.510	17.802	60.083	142.42	278.16	480.66	763.28	1139.4	1622.2	2225.3

落地式精密点胶机PL/OL系列

PL/OL series of floor-standing precision dispensing machine

- ◆ 满足自动化产线作业的点胶机
Dispensing machine for automatic production line operation
- ◆ 满足多种应用工艺
Meet a variety of application processes

产品介绍 Product introduction

丰富产品种类:

Enrich product categories:

PL在线式 四到六轴点胶应用, 单轨道到双轨模块化;

PL online four to six axis dispensing application, single track to double track modularization;

OL离线式 三轴到九轴点胶应用, 满足多行业, 多工艺点胶需求;

OL off-line three-axis to nine-axis dispensing application meets the needs of multi-industry and multi-process dispensing;

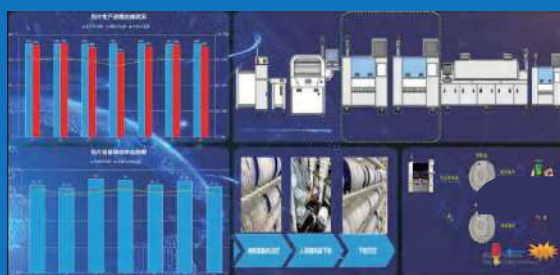

MES管理系统

对接生产排程, 快速变现实生产方案完整存储模块与元件库, 快速变更设备用途科学模拟设备, 准确预见工作目标;科学模拟产线, 完成整线平衡计算与平衡判断离线、在线数据融合, 数据孪生与双向验证实现精益柔性生产。

Docking production scheduling, quickly realizing the complete storage module and component library of production scheme, quickly changing the use of equipment, scientifically simulating equipment, and accurately predicting work objectives; Scientifically simulate the production line, complete the offline and online data fusion of the whole line balance calculation and balance judgment, and realize lean and flexible production by data Li Sheng and two-way verification.



五轴
联动
Five-axis
linkage

在线式精密高速点胶机

On-line precision high-speed dispensing machine

>> S3系列 S3 series



精密点胶机（单轨）
Precision dispensing machine (monorail)



精密点胶机（双轨）
Precision dispensing machine (double track)

喷射阀综合能力 Comprehensive capacity of injection valve

最小点径: 0.15mm
Minimum point meridian: 0.15mm

最小线宽: 0.2mm
Minimum line width: 0.2mm

最小胶量: 0.5nl
Minimum glue amount: 0.5nl

点胶功能可选配置 Optional configuration of dispensing function

- 旋转倾斜系统
Rotating tilt system
- 擦拭系统
Wiping system
- 双阀同步系统
Double valve synchronization system
- 自动电子称
Automatic electronic scale
- 激光测高
Laser altimetry
- 2D检测
2 d detection
- 双阀异步系统
Double valve asynchronous system
- 独立二段式加热
Independent two-stage heating
- 双轨运输系统
Double-track transportation system

PL 应用行业 PL application industry

- 手机边框、PCB、FPC等元器件的底部填充、包封、补强；
Filling, encapsulating and reinforcing the bottom of mobile phone frame, PCB, FPC and other components;
- VCM、CCM、TWS、扬声器、马达等产品的精密点胶；
Precision dispensing of VCM, CCM, TWS, speakers, motors and other products;
- 半导体系统级封装SIP、MEMS的精密点胶、微量点锡膏等；
Semiconductor system-level package SIP, MEMS precision dispensing, micro-dispensing solder paste, etc.



技术参数 technical parameter



产品型号 product model	NS.SP.461HE-PL	NS.SP.4661HE-PL
运动范围 Range of motion	(X/Y/Z) 400/600/50mm	
最大负载 maximum load	(Z 轴) 5KG(选配制动模块可达 7KG) (Z axis) 5KG (up to 7KG with optional brake module)	
移动速度 rate of travel	(X/Y 轴) 0.1-800mm/S (Z 轴) 0.1-400mm/S	
重复精度 repeatability	±0.01mm	
轨道调宽范围 Track width adjustment range	单轨: 60-470mm, 最大点胶长度: 475mm Monorail: 60-470mm, maximum dispensing length: 475mm.	双轨: 60-200mm, 最大点胶长度: 475mm Double track: 60-200mm, maximum dispensing length: 475mm.
对接高度 Docking height	地面到轨道皮带高度: 900mm(±30mm可调) Height of belt from ground to track: 900 mm (adjustable by 30 mm)	
驱动方式 type of drive	伺服电机+丝杆模组 Servo motor+screw module	
传动方式 Transmission mode	步进电机+流道 Stepper motor+runner	
操作模式 operator schema	视觉引导 Visual guidance	
编程模式 Programming mode	键鼠+显示器 Keyboard+display	
视觉定位系统 Visual positioning system	标配高像素工业相机 High-pixel industrial cameras are standard.	
识别范围 Recognition range	30mm*30mm	
功率 power	2000W	
输入电源 Input power supply	AC 110V/220V(内部切换) 50-60HZ	
工作温度 Working temperature	5-40°C/20-90%不结露	
外形尺寸 outline dimension	L840*W1140*H1500mm	
本体重量(kg) Body weight (kg)	约650kg	约800kg
产品特点 Product features	<p>1. 搭载沉重系统, 实现胶量闭环;</p> <p>2. 专业高速点胶系统, 高可控点、直线、多段线、圆弧线、圆、矩形圆形填充三维空间轨迹等全部常见点胶命令工艺;</p> <p>3. 可配置扫码系统, 流水线整线管理一体化;</p> <p>4. 自动快速捕捉Mark定位, 对产品轮廓进行搜索识别, 自动校正补偿, 点胶位置精准;</p> <p>1. Equipped with a heavy system to realize the closed loop of glue quantity;</p> <p>2. Professional high-speed dispensing system, all common dispensing command processes such as high controllable points, straight lines, multi-segment lines, arc lines, circles and rectangular circles filling three-dimensional space trajectories;</p> <p>3 configurable code scanning system, integrated pipeline management;</p> <p>4. Automatically and quickly capture Mark positioning, search and identify the product contour, automatically correct and compensate, and the dispensing position is accurate;</p>	<p>1. 双轨道设计, 效率更高;</p> <p>2. 专业高速点胶系统, 高可控点、直线、多段线、圆弧线、圆、矩形圆形填充三维空间轨迹等全部常见点胶命令工艺;</p> <p>3. 可配置扫码系统, 流水线整线管理一体化;</p> <p>4. 自动快速捕捉Mark定位, 对产品轮廓进行搜索识别, 自动校正补偿, 点胶位置精准;</p> <p>1. Double-track design, higher efficiency;</p> <p>2. Professional high-speed dispensing system, all common dispensing command processes such as high controllable points, straight lines, multi-segment lines, arc lines, circles and rectangular circles filling three-dimensional space trajectories;</p> <p>3 configurable code scanning system, integrated pipeline management;</p> <p>4. Automatically and quickly capture Mark positioning, search and identify the product contour, automatically correct and compensate, and the dispensing position is accurate;</p>

在线式双轨精密高速点胶机

On-line dual-track precision high-speed dispensing machine

>> S6系列 S6 series



(单轨双工位)
(Monorail double station)



(双轨双工位)
(Dual-track dual-station)

喷射阀综合能力 Comprehensive capacity of injection valve

最小点径: 0.15mm

Minimum point meridian: 0.15mm

最小线宽: 0.2mm

Minimum line width: 0.2mm

最小胶量: 0.5nl

Minimum glue amount: 0.5nl

PL 应用行业 PL application industry

- 手机边框、PCB、FPC等元器件的底部填充、包封、补强；
Filling, encapsulating and reinforcing the bottom of mobile phone frame, PCB, FPC and other components;
- VCM、CCM、TWS、扬声器、马达等产品的精密点胶；
Precision dispensing of VCM, CCM, TWS, speakers, motors and other products;
- 半导体系统级封装SIP、MEMS的精密点胶、微量点锡膏等；
Semiconductor system-level package SIP, MEMS precision dispensing, micro-dispensing solder paste, etc.

技术参数 technical parameter



产品型号 product model	NS.SP.461HE-PL	NS.SP.4661HE-PL
运动范围 Range of motion	(X/Y/Z) 400/600/50mm	(X1X2/Y1Y2/Z1Z2) 400/600/50mm
最大负载 maximum load	(Z 轴) 5KG(选配制动模块可达 7KG) (Z axis) 5KG (up to 7KG with optional brake module)	
移动速度 rate of travel	(X/Y 轴) 0.1-800mm/S (Z 轴) 0.1-400mm/S	
重复精度 repeatability	±0.01mm	
轨道调宽范围 Track width adjustment range	单轨: 60-470mm, 最大点胶 长度: 475mm (两侧各伸出机架300mm) Monorail: 60-470mm, maximum length: 475mm (height300mm)	双轨: 60-200mm, 最大点胶 长度: 475mm (两侧各伸出机架300mm) dual-track: 60-470mm, maximum length: 475mm (height300mm)
对接高度 Docking height	地面到轨道皮带高度: 950(±20mm可调) Height of belt from ground to track: 950(±20mm adjustable)	
驱动方式 type of drive	伺服电机+丝杆模组 Servo motor+screw module	
传动方式 Transmission mode	步进电机+流道 Stepper motor+runner	
操作模式 operator schema	视觉引导 Visual guidance	
编程模式 Programming mode	键鼠+显示器 Keymouse+display	
视觉定位系统 Visual positioning system	标配高像素工业相机 High-pixel industrial cameras are standard.	
识别范围 Recognition range	30mm*30mm	
功率 power	2000W	
输入电源 Input power supply	AC 110V/220V(内部切换) 50-60HZ	
工作环境温度湿度 Working environment humidity	5-40°C/20-90%不结露	
外形尺寸 outline dimension	L1600*W1140*H1500mm	
本体重量(kg) Body weight (kg)	约1000kg	约1200kg
产品特点 Product features	1.高效率, 两套独立的XYZ运动系统同时作业, 效率提升80%以上; 2.高精度全系统点胶, 包括胶点和胶线; 3.一机多用, 可同时对两种不同的点胶工艺进行生产作业; 闭环工艺控制在持续的生产中保证点胶胶量的一致性; 4.集成视觉系统, 提供同轴或离轴照明方式, 可编程控制的双轴倾斜选件; 1. High efficiency, two sets of independent XYZ motion systems work at the same time, and the efficiency is improved by more than 80%; 2. High-precision whole system dispensing, including glue points and glue lines; 3. One machine can be used for multiple purposes, and two different dispensing processes can be produced simultaneously; Closed-loop process control ensures the consistency of dispensing amount in continuous production; 4. Integrated vision system, providing coaxial or off-axis illumination mode and programmable dual-axis tilt option;	1.高效率, 两套独立点胶系统同时作业, 高精度, 双阀采用异步运动控制; 2.一机多用, 可同时对两种不同的点胶工艺进行生产作业; 工艺控制在持续的生产中保证点胶胶量的一致性; 3.可配置扫码系统, 流水线整线管理一体化; 4.自动快速捕捉Mark定位, 对产品轮廓进行搜索识别, 自动校正补偿, 点胶位置精准; 1. High efficiency, simultaneous operation of two independent dispensing systems, high precision, and asynchronous motion control of double valves; 2. One machine can be used for multiple purposes, and two different dispensing processes can be produced simultaneously; Process control ensures the consistency of dispensing amount in continuous production; 3 configurable code scanning system, integrated pipeline management; 4. Automatically and quickly capture Mark positioning, search and identify the product contour, automatically correct and compensate, and the dispensing position is accurate;

在线式双Y五轴联动高速点胶机

On-line double Y five-axis linkage high-speed dispensing machine

> >S8系列

产品特点 Product features

- 1.高精度,真五轴联动控制系统,可选择搭配3D在线扫码相机做引导点胶机胶路检查功能;
- 2.高效率,双工位设计,点胶与CCD定位/3D扫描同步作业;
- 3.双平台交替作业,设有取放料时间,效率高;
- 4.全自动,无需人工上下料,可连接上下游设备使用,生产效率高;

1. High-precision, true five-axis linkage control system, which can be matched with 3D on-line code scanning camera to guide the glue line inspection function of the glue dispenser;
2. High efficiency, double-station design, simultaneous operation of dispensing and CCD positioning /3D scanning;
3. Double-platform alternate operation, with feeding and discharging time, high efficiency;
4. Fully automatic, without manual loading and unloading, and can be connected with upstream and downstream equipment for use, with high production efficiency;



技术参数 technical parameter

产品名称 product name	在线式双Y五轴联动高速点胶机 On-line double Y five-axis linkage high-speed dispensing machine
产品型号 product model	NS.SP.5442HE-PL-AV
运动范围 Range of motion	(X/Y/Z/A/V) 200*200*200*360°*360°
点胶有效范围 Effective range of dispensing	XY轴: 250mm
A/V旋转轴重复精度 A/V rotation axis repeatability accuracy	±2 arc sec
最大负载 maximum load	(Z轴) 3.5KG
移动速度 rate of travel	(X/Y轴) 0.1-800mm/S, (Z轴) 0.1-600mm/S
重复精度 repeatability	±0.01mm
轨道调宽范围 Track width adjustment range	配置双轨, 单个轨道可调范围: 60-120mm Equipped with double tracks, single track adjustable range: 60-120mm.
对接高度 Docking height	地面到轨道皮带高度: 950mm(可调) Height of belt from ground to track: 950mm (adjustable)
驱动方式 type of drive	高精度交流伺服系统 High precision AC servo system
传动方式 Transmission mode	伺服电机+丝杆模组+直线电机 Servo motor+screw module+linear motor
视觉定位系统 Visual positioning system	标配高像素工业相机 High-pixel industrial cameras are standard.
控制方式 Control mode	多轴运动控制卡 Multi-axis motion control card
辅助条件 Auxiliary condition	自动称重/自动测高/自动擦胶 Automatic weighing/height measurement/glue wiping
操作系统 operating system	工业控制电脑 Industrial control computer
识别范围 Recognition range	30MM*30MM
输入电源 Input power supply	AC110V/220V/50-60HZ 1.5kW
工作环境温度湿度 Working environment humidity	5-40°C/20-90%
外型尺寸 External dimension	L1980*W1400*H1700mm
本体重量 Body weight	约1000KG

在线式新能源FPC/CCS高速点胶机

On-line new energy FPC/CCS high-speed dispensing machine

> >S9系列

■ 新能源汽车FPC/CCS超长点胶应用
Application of FPC/CCS super-long dispensing for new energy vehicles

产品特点 Product features

- 1.提高点胶品质，减少气泡和散点产生，弥补原有设备和工艺的不足；
- 2.精确的胶量控制，确保点胶区域表面一致性和胶水重量的一致性，提高品质，高速和高频率的点胶实现产能的提升，加快设备投入的成本回收；
- 3.新型数字视觉系统，实现高速Mark点、芯片边角基准点捕获，提高点胶轨迹精度；配有专用传送带、轨道压边和多模式顶升平台，轻松应对各种异形点胶部件或载具；
- 4.阀体模组：双压电阀动态模组、双针阀同步模组、压电阀和针阀异步模组；

1. Improve the dispensing quality, reduce the generation of bubbles and scattered points, and make up for the shortcomings of the original equipment and technology;
2. Accurate glue quantity control, ensuring the consistency of the surface of the glue dispensing area and the consistency of the glue weight, improving the quality, improving the production capacity by high-speed and high-frequency glue dispensing, and accelerating the cost recovery of equipment investment;
3. A new digital vision system, which can capture high-speed Mark points and chip corner reference points and improve the accuracy of dispensing trajectory; Equipped with special conveyor belt, rail blank holder and multi-mode jack-up platform, it can easily deal with all kinds of special-shaped dispensing parts or vehicles;
4. Valve body module: double piezoelectric valve dynamic module, double needle valve synchronous module, piezoelectric valve and needle valve asynchronous module;



技术参数 technical parameter

产品型号 product model	NS.SP.9551A-PL-2T
运动范围 Range of motion	单阀: X=1800,Y=600,Z=100mm(可分段点胶)
移动速度 rate of travel	1000mm/S
重复精度 repeatability	±0.02mm
最大加速度 Maximum acceleration	0.8G
驱动方式 type of drive	高精度交流伺服系统(最高配24位编码器) High precision AC servo system (up to 24-bit encoder)
操作模式 operator schema	工业控制电脑 Industrial control computer
传动方式 Transmission mode	伺服精密马达+精密丝杠模组 Servo precision motor+precision screw module
输送高度/调宽模式 Conveying height/width adjustment mode	900+20mm/400mm
控制方式 Control mode	多轴运动控制卡 Multi-axis motion control card
编程模式 Programming mode	键鼠+显示器 Keymouse+display
视觉分辨率 Visual resolution	0.01*0.01mm/Pixel
输入电源 Input power supply	AC220V 50/60HZ
工作环境温度湿度 Working environment temperature and humidity	5-40°C/20-90%
外型尺寸 External dimension	设备本体长2500mm The equipment body is 2500mm long
本体重量 Body weight	约1000KG

在线式五轴炉后点胶机

On-line five-axis glue dispenser behind furnace

>>D5-AV系列

产品特点 Product features

1. 头部针头旋转点胶；
2. 专业高速点胶系统，高可控点、直线、多段线、圆弧线、圆、矩形圆形填充三维空间轨迹等全部常见点胶命令工艺；
3. 可配置扫码系统，流水线整线管理一体化；
4. 自动快速捕捉Mark定位，对产品轮廓进行搜索识别，自动校正补偿，点胶位置精准，适用于后段补偿硅胶多高度点胶；

1. The head needle rotates to dispense glue;
2. Professional high-speed dispensing system, all common dispensing command processes such as high controllable points, straight lines, multi-segment lines, arc lines, circles and rectangular circles filling three-dimensional space trajectories;
3. Configurable code scanning system and integrated pipeline management;
4. Automatically and quickly capture the positioning of Mark, search and identify the product contour, automatically correct and compensate, and the dispensing position is accurate, which is suitable for the multi-height dispensing of the post-compensation on silicone;



基础配置 Basic configuration

- 五轴运动平台/单轨输送
Five-axis motion platform/monorail transportation

技术参数 technical parameter

产品名称 product name	在线式五轴炉后点胶机 On-line five-axis glue dispenser behind furnace		
产品型号 product model	NS.SP.551HE-R-PL		
运动范围 Range of motion	(XYZ)500*500*100mm R轴旋转: 360°		
最大负载 maximum load	(Y/Z) 5KG		
移动速度 rate of travel	(X/Y轴) 0.1-600mm/S, (Z轴) 0.1-300mm/S		
重复精度 repeatability	±0.01mm		
对接高度 Docking height	地面到轨道皮带高度: ±900mm(20mm可调) Height of belt from ground to track: 900 mm (adjustable by 20 mm)		
轨道调宽范围 Track width adjustment range	单轨: 50-450mm Monorail: 50-450mm		
驱动方式 type of drive	高精度交流伺服系统 High precision AC servo system		
传动方式 Transmission mode	丝杆模组 Screw module		
编程模式 Programming mode	人机触控界面 Man-machine touch interface		
视觉定位系统 Visual positioning system	标配132万像素工业相机(像素可选: 3M或5M) Standard 1.32 million pixel industrial camera (pixel optional: 3M or 5M)		
视觉分辨率 Visual resolution	0.01*0.01mm/Pixel(可调)		
识别范围 Recognition range	14*14mm		
输入电源 Input power supply	220V		
工作环境温度湿度 Working environment humidity	5-40°C/20-90%不结露		
外型尺寸 External dimension	L1040*W1050*H1700mm	本体重量 Body weight	约100KG

在线式三轴点胶机

On-line three-axis dispensing machine

>>D3系列

产品特点 Product features

- 1.智能视觉点胶系统，配合MARK 拍照实时定位纠正点胶轨迹，引导点胶；
- 2.在线式搭配流水线整线生产提高产能；
- 3.搭载喷射阀功能模块，非接触式点胶，实现更小的点胶直径，也可搭载其他点胶阀方式，以及更广的适用领域；
- 4.适用于后段补偿硅胶的高度点胶；

1. Intelligent vision dispensing system, which coordinates with MARK to take photos, position and correct dispensing trajectory in real time, and guide dispensing;
2. On-line production with assembly line to improve production capacity;
3. Equipped with injection valve function module and non-contact dispensing to realize smaller dispensing diameter, and can also be equipped with other dispensing valves and wider application fields;
4. It is suitable for the height dispensing of post-compensation silica gel;



基础配置 Basic configuration

- 三轴运动平台/单轨输送
Three-axis moving platform/monorail transportation

技术参数 technical parameter

产品名称 product name	在线式三轴点胶机 On-line three-axis dispensing machine
产品型号 product model	NS.SP.451H-PL
运动范围 Range of motion	(XYZ)400*500*100mm
最大负载 maximum load	(Y/Z) 5KG
移动速度 rate of travel	(X/Y 轴) 0.1-600mm/S, (Z 轴) 0.1-300mm/S
重复精度 repeatability	±0.01mm
对接高度 Docking height	单轨: 50-350mm Monorail: 50-350mm
轨道调宽范围 Track width adjustment range	地面到轨道皮带高度: ±900mm(30mm可调) Height of belt from ground to track: 900 mm (adjustable by 30 mm)
驱动方式 type of drive	高精度交流伺服系统 High precision AC servo system
传动方式 Transmission mode	丝杆模组 Screw module
编程模式 Programming mode	人机界面CCD辅助 Man-machine interface CCD assisted
输入电源 Input power supply	220V
工作环境温度湿度 Working environment humidity	5-40°C/20-90% 不结露
外型尺寸 External dimension	L860*W1000*H1700mm
本体重量 Body weight	约100KG

在线等离子表面活化处理

On-line plasma surface activation treatment

■ 用途：材料表面清洗活化

Uses: surface cleaning and activation of materials

产品特点 Product features

1. 对接前后线体，在线作业，真空腔体清洗物料；
2. 可同时接入两种气体以上；
3. 可以与产线对接实现自动化生产作业，二维码扫码上传；

1. Docking the front and rear wire bodies, working online, and cleaning materials in a vacuum cavity;
2. More than two gases can be connected at the same time;
3. Automatic production operation can be realized by docking with the production line, and the QR code can be scanned and uploaded;



应用案例 Application case



技术参数 technical parameter

产品名称 product name	在线等离子表面活化处理 On-line plasma surface activation treatment
产品型号 product model	NS.FB.461
运动范围 Range of motion	(XYZ) 400*600*100mm
最大负载 maximum load	(Y/Z) 20KG/15KG
移动速度 rate of travel	(XY/Z) 0.1-600mm/s (2)0.1-300mm/s
重复精度 repeatability	0.02mm
对接高度 Docking height	地面到轨道皮带高度：±950mm(20mm可调) Height of belt from ground to track: 950 mm (adjustable by 20 mm)
驱动方式 type of drive	高精度交流伺服系统（配17-24位编码器） High precision AC servo system (with 17-24 bit encoder)
传动方式 Transmission mode	皮带模组 Belt module
控制方式 Control mode	运动控制器 Motion controller
编程模式 Programming mode	手编器 Hand knitting machine
输入电源 input power supply	AC110V/220V/50-60HZ 1.5kW
工作环境温度湿度 Working environment humidity	5-40°C/20-90% 不结露
外型尺寸 External dimension	L840*W1100*H1600mm
本体重量 Body weight	600Kg

在线式胶路AOI检测

On-line AOI detection of rubber road

双轨道单工作平台实施检测

Double-track single working platform carries out inspection

产品特点 Product features

- 1.断胶检测:全覆盖式检测产品有无断胶;
- 2.胶型检测:全覆盖式检测产品胶型轮廓, 不限于直线、弧线段的胶条宽度及胶条高度检测, 搭接点(T型、十型、L型等)胶条高度检测、断胶检测;

1. Glue breakage detection: full coverage detection of whether the product has glue breakage;
2. Rubber type detection: the rubber profile of the product is fully covered, not limited to the detection of the width and height of the rubber strip in the straight line and arc section, the detection of the height of the rubber strip in the lap joint (T-type, X-type, L-type, etc.) and the detection of broken rubber;



应用案例 Application case



技术参数 technical parameter

产品名称 product name	在线胶路AOI检测 On-line rubber road AOI detection
产品型号 product model	NS.FB.461HE-3D.AOI
运动范围 Range of motion	X1X2轴400mm, Y1Y2200mm,Z1Z2轴100mm, 旋转: 360°
最大负载 maximum load	5KG
移动速度 rate of travel	(X/Y轴) 0.1-600mm/S, (Z轴) 0.1-300mm/S
重复精度 repeatability	±0.01mm
对接高度 Docking height	地面到轨道皮带高度: ±950mm(20mm可调) Height of belt from ground to track: 950 mm (adjustable by 20 mm)
驱动方式 type of drive	高精度交流伺服系统 High precision AC servo system
传动方式 Transmission mode	丝杆模组 Screw module
控制方式 Control mode	运动控制器 Motion controller
视觉检测系统 Visual inspection system	激光三维轮廓测量仪 Laser three-dimensional profilometer
编程模式 Programming mode	人机触控界面 Man-machine touch interface
工作环境温度湿度 Working environment humidity	220V 5-40°C/20-90% 不结露
外型尺寸 External dimension	L1190*W1360*H1670mm
本体重量 Body weight	500kg

整线应用解决方案

Whole line application solution

- 可一台设备和功能模块生产需求，即可实现小批量，多种产品生产；
- 根据产能需求和线路平衡，采用多单元自动化和各种动能模块的组合实现量产目的，只需更换自动化模块即可更换生产线，无需移动设备；
- 也可拓展更多自动化模块生产线，定制产线布局，选择功能模块，为生产线快速建设提供一站式自动化整体解决服务；

Can meet the production requirements of one equipment and functional module, which can realize small batch and multiple product production;

According to the capacity demand and line balance, multi-unit automation and various kinetic energy modules are combined to achieve mass production, and the production line can be replaced only by replacing the automation module without moving equipment; Can also expand more automation module production lines, customize the layout of production lines, select functional modules, and provide one-stop automated overall solution services for the rapid construction of production lines;

在线式高速点胶机整体解决方案(S3系列)

Overall solution of online high-speed dispensing machine (S3 series)

工作台：上板机→点胶机→等离子→UV固化→下板机

Workbench: loading machine → dispensing machine → plasma → UV curing → unloading machine.



3C/手机平板点胶应用解决方案(S6系列)

3C/Mobile Phone Flat Dispensing Application Solution (S6 Series)

工作台：等离子清洗→双轨点胶机→AOI胶路检测机

Workbench: plasma cleaning → double-track glue dispenser → AOI glue path detector.



在线式双Y五轴联动应用解决方案(S8系列)

On-line double Y five-axis linkage application solution (S8 series)

工作台：上料机→点胶机→缓存机→点胶机→翻板机→点胶机→下料机

Workbench: feeder → dispenser → buffer → dispenser → turnover machine → dispenser → unloader.

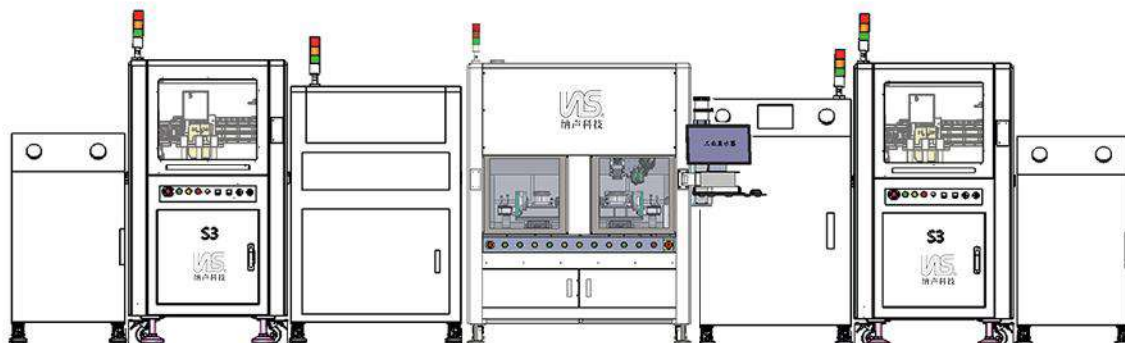

新能源FPC/CCS超长点胶/UV固化解决方案(S9系列)

New Energy FPC / CCS Super Long Dispensing / UV Curing Solution (S9 Series)

工作台：上板机→点胶机→UV固化

Workbench: loading machine → dispensing machine → UV curing.

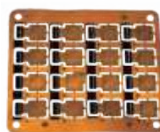

三轴高速精密点胶机

Three-axis high-speed precision dispensing machine

> >N3系列

产品特点

Features

1. 自动快速捕捉Mark定位，对产品轮廓进行搜索识别，自动校正补偿，点胶位置精准；
2. 专业搭载喷射阀功能模块，非接触式点胶，实现更小的点胶直径，也可搭载、其他点胶阀方式，以及更广的适用领域；
3. 各个轴的行程、运动速度和加速度，均可按要求定制；
4. MES、胶阀、对针传感器、Ethernet、五轴联动旋转轴、扫码枪可升级；

1. Automatically and quickly capture Mark positioning, search and identify the product contour, automatically correct and compensate, and the dispensing position is accurate;
2. Professional equipped with injection valve function module, non-contact dispensing, realizing smaller dispensing diameter, also equipped with other dispensing valves, and wider application fields;
3. The travel, movement speed and acceleration of each axis can be customized as required;
4. MES, glue valve, alignment sensor, Ethernet, five-axis rotating shaft and scanning code gun can be upgraded;



可选功能配置

Optional function configuration

- 激光测高仪
Laser altimeter
- 自动称重天平
Automatic weighing balance
- 胶水液体检测
Glue liquid detection
- 喷胶阀/精密螺杆阀
Glue spraying valve/precision screw valve
- 擦胶结构
Rubber wiping structure
- 对针模块
Needle alignment module
- 2DAOI检测
2DAOI detection

可拓展平台

Scalable Platform

- 旋转工位，实现多角度全方位的点胶应用
Rotating station, realizing multi-angle and omni-directional dispensing application
- AV旋转结构
AV rotating structure

产品定位

Product Positioning

落地式离线式点胶机，简约大气，平台标准化、功能模块化、模块通用化技术，满足电声、3C、通讯、家电等行业

Floor-standing off-line dispensing machine, simple and atmospheric, platform standardization, modular function and modular generalization technology, meets the needs of electroacoustic, 3C, communication, household appliances and other industries.



技术参数 technical parameter

N3系列
N3 series

产品名称 product name	三轴高速精密点胶机 Three-axis high-speed precision dispensing machine		
产品型号 product model	NS431HE	NS552HE	NS552HE-AV
运动范围 Range of motion	400*300*100mm	500*500*200mm	500*500*200mm*A360°/V360°
A/V旋转轴重复精度 A/v rotation axis repeatability accuracy			±2 arc sec
最大负载 maximum load	(Y/Z) 20KG/15KG		
移动速度 rate of travel	(x/Y) 0.1-600mm/s (Z)01-300mm/s		
重复精度 repeatability	±0.01mm		
存储内存 Storage memory	64G/120G		
驱动方式 type of drive	高精度交流伺服系统 (最高配24位编码器) High precision AC servo system (up to 24-bit encoder)		
操作模式 operator schema	工业控电脑 Industrial control computer		
传动方式 Transmission mode	静音丝杠精密模组(研磨级) Silent lead screw precision module (grinding stage)		
视觉定位系统 Visual positioning system	标配高像素工业相机 High-pixel industrial cameras are standard		
控制方式 Control mode	多轴运动控制卡 Multi-axis motion control card		
编程模式 Programming mode	键鼠+显示器 Keymouse+display		
视觉分辨率 Visual resolution	0.010.01mm/Pixel		
识别范围 Recognition range	14*14mm		
输入电源 Input power supply	AC110W1220V/50-60HZ1.5kw		
工作环境温度湿度 Working environment humidity	5-40C/20-90%		
外型尺寸 External dimension	WLH:810*810*1700mm		
本体重量 Body weight	约200Kg	约250Kg	约270Kg

双Y精密点胶机

Double y precision dispensing machine

>>N4系列

产品特点

Features

- 1.自动快速捕捉Mark定位，对产品轮廓进行搜索识别，自动校正补偿，点胶位置精准；
- 2.专业搭载喷射阀功能模块，非接触式点胶，实现更小的点胶直径，也可搭载、其他点胶阀方式，以及更广的适用领域；
- 3.各个轴的行程、运动速度和加速度，均可按要求定制；
- 4.MES、胶阀、对针传感器、Ethernet、扫码枪可升级；

1. Automatically and quickly capture Mark positioning, search and identify the product contour, automatically correct and compensate, and the dispensing position is accurate;
2. Professional equipped with injection valve function module, non-contact dispensing, realizing a smaller dispensing diameter, also equipped with other dispensing valves, and wider application fields;
3. The travel, movement speed and acceleration of each axis can be customized as required;
4. MES, glue valve, alignment sensor, Ethernet and scanning code gun can be upgraded;



可选功能配置

Optional function configuration

- 激光测高仪
Laser altimeter
- 自动称重天平
Automatic weighing balance
- 胶水液体检测
Glue liquid detection
- 喷胶阀/精密螺杆阀
Glue spraying valve/precision screw valve
- 擦胶结构
Rubber wiping structure
- 对针模块
Needle alignment module
- 2DAOI检测
2DAOI detection

可拓展平台

Scalable Platform

- 旋转工位，实现多角度全方位的点胶应用
Rotating station, realizing multi-angle and omni-directional dispensing application
- AV旋转结构
AV rotating structure

产品定位

Product Positioning

落地式离线式点胶机，简约大气，平台标准化、功能模块化、模块通用化技术，满足电声、3C、通讯、家电等行业

Floor-standing off-line dispensing machine, simple and atmospheric, platform standardization, modular function and modular generalization technology, meets the needs of electroacoustic, 3C, communication, household appliances and other industries.



技术参数 technical parameter

N4系列
N4 series

产品名称 product name	双Y精密点胶机	
产品型号 product model	NS4331HE	NS5552HE
运动范围 Range of motion	400*300*300*100mm	500*500*500*200mm
最大负载 A/v rotation axis repeatability accuracy	(Y/Z) 20KG/15KG	
移动速度 maximum load	(x/Y) 0.1-600mm/s (Z) 0.1-300mm/s	
重复精度 rate of travel	±0.01mm	
存储内存 repeatability	64G/120G	
驱动方式 Storage memory	高精度交流伺服系统 (最高配24位编码器) High precision AC servo system (up to 24-bit encoder)	
操作模式 operator schema	工业控电脑 Industrial control computer	
传动方式 Transmission mode	静音丝杠精密模组(研磨级) Silent lead screw precision module (grinding stage)	
视觉定位系统 Visual positioning system	标配高像素工业相机 High-pixel industrial cameras are standard	
控制方式 Control mode	多轴运动控制卡 Multi-axis motion control card	
编程模式 Programming mode	键鼠+显示器 Keymouse+display	
视觉分辨率 Visual resolution	0.010.01mm/Pixel	
识别范围 Recognition range	14*14mm	
输入电源 Input power supply	AC110W1220V/50-60HZ1.5kw	
工作环境温度湿度 Working environment humidity	5-40C/20-90%	
外型尺寸 External dimension	WLH:810*810*1700mm	
本体重量 Body weight	约200Kg	约280Kg

五轴联动精密点胶机

Five-axis linkage precision dispensing machine

■ 多姿态点胶轨迹联动

Multi-pose dispensing trajectory linkage

>>N3-pro系列

产品特点

Features

- 1.采用3次空间样条曲线插补技术，轨迹加工精度为0.03mm；
- 2.五轴轨迹速度二阶连续，胶状均匀，拐角无堆胶；
- 3.五轴设备参数视觉自动测量，提高装机效率，精度可达0.03mm；
- 4.采用视觉技术纠正产品装夹误差，精度最高为0.01mm；
- 5.设备最高空移速度可达800mm/s，轨迹加工最高速度为200mm/s；
- 6.胶水厚度控制0.2mm以内；
- 7.用软件空间样条曲线运动插补技术算法配合视觉辅助示教引导，实现空间曲线精准顺畅点胶；

1. Using cubic space spline curve interpolation technology, the machining accuracy of trajectory is 0.03mm;
2. The five-axis trajectory speed is second-order continuous, and the glue is even, and there is no glue accumulation at the corner;
3. Visual automatic measurement of five-axis equipment parameters improves the installation efficiency, and the accuracy can reach 0.03mm;
4. Using vision technology to correct the product clamping error, with the highest accuracy of 0.01mm;
5. The highest idle speed of the equipment can reach 800 mm/s, and the highest speed using is 200 mm/s;
6. Glue thickness should be controlled within 0.2mm;
7. Using software spatial spline curve motion interpolation technology algorithm and visual aided teaching guidance to realize accurate and smooth dispensing of spatial curve;



基础配置

Basic configuration

- 五轴运动平台
Five-axis motion platform
- 视觉识别点胶系统
Visual recognition dispensing system
- 针筒
needle tubing
- AV旋转结构
AV rotating structure

可选配

Optional

高灵活性：可配各种阀体，如喷射阀、压电阀、螺杆阀、针对客户需求，灵活选用，各类功能模块高度集成，可进行选配

High flexibility: it can be equipped with various valve bodies, such as injection valve, piezoelectric valve and screw valve, which can be selected flexibly according to customer's needs. Various functional modules are highly integrated and can be selected.

- 针头校正
Needle correction
- 液位检测
Liquid level detection
- 胶量称重
Glue weighing
- 3D激光测高
3D altimetry
- 信息扫描
Message scanning
- 喷胶清洁
Glue spraying cleaning

产品定位

Product positioning

落地式离线式点胶机，简约大气，平台标准化、功能模块化、模块通用化技术，满足电声、3C、通讯、家电等行业

Floor-standing off-line dispensing machine, simple and atmospheric, platform standardization, modular function and modular generalization technology, meets the needs of electroacoustic, 3C, communication, household appliances and other industries.



技术参数 technical parameter

N3-Pro系列
N4-proseries

产品名称 product name	五轴联动精密点胶机 Five-axis linkage precision dispensing machine	
产品型号 product model	NS552HHE	NS552HHE-AV
运动范围 Range of motion	500*500*200mm	500*500*500*200mm A360°/V*360°
A/V旋转轴重复精度 A/v rotation axis repeatability accuracy		±2 arc sec
最大负载 maximum load	(Y/Z) 20KG/15KG	
移动速度 rate of travel	(x/Y) 0.1-1000mm/s (Z) 0.1-300mm/s	
重复精度 repeatability	±0.01mm	
存储内存 Storage memory	64G/120G	
驱动方式 type of drive	高精度交流伺服系统（最高配24位编码器） High precision AC servo system (up to 24-bit encoder)	
操作模式 operator schema	工业控电脑 Industrial control computer	
传动方式 Transmission mode	静音丝杠精密模组(研磨级) Silent lead screw precision module (grinding stage)	
视觉定位系统 Visual positioning system	标配高像素工业相机 High-pixel industrial cameras are standard	
控制方式 Control mode	多轴运动控制卡 Multi-axis motion control card	
编程模式 Programming mode	键鼠+显示器 Keymouse+display	
视觉分辨率 Visual resolution	0.010.01mm/Pixel	
识别范围 Recognition range	14*14mm	
输入电源 Input power supply	AC110W1220V/50-60HZ1.5kw	
工作环境温度湿度 Working environment humidity	5-40C/20-90%	
外型尺寸 External dimension	WLH:810*960*1700mm	
本体重量 Body weight	约200Kg	约220Kg

高速精密点胶机

High-speed precision dispensing machine

> >N5-pro系列

产品特点

Features

- 1.采用3次空间样条曲线插补技术，轨迹加工精度为0.03mm；
- 2.五轴轨迹速度二阶连续，胶状均匀，拐角无堆胶；
- 3.五轴设备参数视觉自动测量，提高装机效率，精度可达0.03mm；
- 4.采用视觉技术纠正产品装夹误差，精度最高为0.01mm；
- 5.设备最高空移速度可达800mm/s，轨迹加工最高速度为200mm/s；
- 6.用软件空间样条曲线运动插补技术算法配合视觉辅助示教引导，实现空间曲线精准顺畅点胶；

1. Using cubic space spline curve interpolation technology, the machining accuracy of trajectory 0.03mm;
2. The five-axis trajectory speed is second-order continuous, and the glue is even, and there is no glue accumulation at the corner;
3. Visual automatic measurement of five-axis equipment parameters improves the installation efficiency, and the accuracy can reach 0.03mm; 4. Using vision technology to correct the product clamping error, with the highest accuracy of 0.01mm;
5. The highest idle speed of the equipment can reach 800 mm/s, and the highest speed of trajectory processing is 200 mm/s;
6. Using software spatial spline curve motion interpolation technology algorithm and visual aided teaching guidance to realize of spatial curve;



基础配置

Basic configuration

- 五轴运动平台 Five-axis motion platform
- 视觉识别点胶系统 Visual recognition dispensing system
- 清胶校准模块 Glue cleaning calibration module
- 针筒 needle tubing
- 大理石平台 Marble platform

可选配

Optional

高灵活性：可配各种阀体，如喷射阀、压电阀、螺杆阀，针对客户需求，灵活选用，各类功能模块高度集成，可进行选配

High flexibility: it can be equipped with various valve bodies, such as injection valve, piezoelectric valve and screw valve, which can be selected flexibly according to customer's needs. Various functional modules are highly integrated and can be selected.

- 针头校正 Needle correction
- 液位检测 Needle correction
- 胶量称重 Glue weighing
- 3D激光测高 3D laser altimetry
- 信息扫描 Message scanning
- AV旋转结构 AV rotating structure

产品定位

Product Positioning

落地式离线式点胶机，简约大气，平台标准化、功能模块化、模块通用化技术，满足电声、3C、通讯、家电等行业

Floor-standing off-line dispensing machine, simple and atmospheric, platform standardization, modular function and modular generalization technology, meets the needs of electroacoustic, 3C, communication, household appliances and other industries.



技术参数 technical parameter

N5-Pro系列
N5-proseries

产品名称 product name	高速精密点胶机 High-speed precision dispensing machine		
产品型号 product model	NS5552HHE	NS8552HHE	NS8552HHE-AV
运动范围 Range of motion	(X/Y1Y2/Z/) 500*500*500*200mm	(X/Y1Y2/Z/) 800*500*500*200mm	(X/Y1Y2/Z/A1/V1/A2/V2) 800*500*500*200mm360°*360°*360°
A/V旋转轴重复精度 A/v rotation axis repeatability accuracy			±2 arc sec
最大负载 maximum load	(Y/Z) 20KG/15KG		
移动速度 rate of travel	(XY) 0.1-1000mm/s (Z)0.1-300mm/s		
重复精度 repeatability	±0.01mm		
存储内存 Storage memory	500G		
驱动方式 type of drive	XY:直线电机 Z:伺服电机 XY: linear motor z: servo motor		
操作模式 operator schema	工业控制电脑 Industrial control computer		
传动方式 Transmission mode	静音丝杠精密模组(研磨级) Silent lead screw precision module (grinding stage)		
视觉定位系统 Visual positioning system	2D相机 2D camera		
控制方式 Control mode	多轴运动控制卡 Multi-axis motion control card		
编程模式 Programming mode	键鼠+显示器 Keymouse+display		
视觉分辨率 Visual resolution	0.01*0.01mm/Pixel(可调)		
识别范围 Recognition range	14*14mm		
输入电源 Input power supply	AC220V/50-60HZ/1.5kw		
工作环境温度湿度 Working environment humidity	5-40°C/20-90%不结露		
外型尺寸 External dimension	L1200*W1300*H1900mm		
本体重量 Body weight	约800Kg	约900Kg	约920Kg

双Y五轴联动高速精密点胶机

Double y five-axis linkage high-speed precision dispensing machine

>>N8-pro系列

产品特点

Features

- 1.高精度，五轴联动控制系统，可选择搭配3D线扫相机做引导点胶胶路检测检查功能；
- 2.可离线人工上下料单机生产，或配置进出料轨道，连接上下游设备在线生产；
- 3.高效率，双工位设计点胶与CCD定位/3D扫码同步作业；

1. High-precision, five-axis linkage control system, which can optionally be matched with 3D line scanning camera to do the inspection function of guiding glue dispensing;
2. Off-line manual feeding and discharging can be carried out on a single machine, or feeding and discharging tracks can be configured to connect upstream and downstream equipment for online production;
3. High efficiency, double-station design, simultaneous operation of dispensing and CCD positioning/3D code scanning;



基础配置

Basic configuration

- 五轴运动平台
Five-axis motion platform
- 视觉识别点胶系统
Visual recognition dispensing system
- 清胶校准模块
Glue cleaning calibration module
- 针筒
needle tubing
- 大理石平台
Marble platform
- AV旋转结构
AV rotating structure

可选配

Optional

高灵活性：可配各种阀体，如喷射阀、压电阀、螺杆阀、针对客户需求，灵活选用，各类功能模块高度集成，可进行选配

High flexibility: it can be equipped with various valve bodies, such as injection valve, piezoelectric valve and screw valve, which can be selected flexibly according to customer's needs. Various functional modules are highly integrated and can be selected.

- 针头校正
Needle correction
- 液位检测
Needle correction
- 胶量称重
Glue weighing
- 3D激光测高
3D laser altimetry
- 信息扫描
Message scanning

产品定位

Product Positioning

落地式离线式点胶机，简约大气，平台标准化、功能模块化、模块通用化技术，满足电声、3C、通讯、家电等行业

Floor-standing off-line dispensing machine, simple and atmospheric, platform standardization, modular function and modular generalization technology, meets the needs of electroacoustic, 3C, communication, household appliances and other industries.



技术参数 technical parameter

N8-Pro系列
N5-proseries

产品名称 product name	双Y五轴联动高速精密点胶机 Double y five-axis linkage high-speed precision dispensing machine	
产品型号 product model	NS8552HHE	NS8552HHE-AV
运动范围 Range of motion	(X/Y1Y2/Z/A1/V1/A2/V2) 800*500*500*200mm	(X/Y1Y2/Z/A1/V1/A2/V2) 800*500*500*200*360°*360°*360°*360°
A/V旋转轴重复精度 A/v rotation axis repeatability accuracy		±2 arc sec
最大负载 maximum load	(Y/Z) 20KG/15KG	
移动速度 rate of travel	(XY) 0.1-1000mm/s (Z)0.1-300mm/s	
重复精度 repeatability	±0.01mm	
存储内存 Storage memory	500G	
驱动方式 type of drive	XY:直线电机 Z:伺服电机 XY: linear motor z: servo motor	
操作模式 operator schema	工业控制电脑 Industrial control computer	
传动方式 Transmission mode	静音丝杠精密模组 (研磨级) Silent lead screw precision module (grinding stage)	
视觉定位系统 Visual positioning system	2D相机 2D camera	
控制方式 Control mode	多轴运动控制卡 Multi-axis motion control card	
编程模式 Programming mode	键鼠+显示器 Keypress+display	
视觉分辨率 Visual resolution	0.01*0.01mm/Pixel(可调)	
识别范围 Recognition range	14*14mm	
输入电源 Input power supply	AC110V/220V/50-60HZ 1.5kW	
工作环境温度湿度 Working environment humidity	5-40°C/20-90% 不结露	
外型尺寸 External dimension	L1500*W1300*H1900mm	
本体重量 Body weight	约800KG	约820KG

灌胶机应用系列

Application series of glue filling machine

产品介绍 Product introduction

AB双液胶灌胶机，是专门对流体进行控制，并将液体点滴、涂覆、灌封于产品表面或产品内部的自动化机器，使其达到密封、固定、防水等作用的设备，一般使用的多为双组份胶水。主要用于产品工艺中的胶水、油以及其他液体的粘接、灌注、涂层、密封、填充，自动化灌胶机能够实现点、线、弧、圆等不规则图形的灌胶。

AB two-liquid glue filling machine is an automatic machine that controls the fluid and drips, coats and seals the liquid on the surface or inside the product to achieve the functions of sealing, fixing and waterproofing. Generally, two-component glue is used. It is mainly used for bonding, pouring, coating, sealing and filling of glue, oil and other liquids in product technology. The automatic glue filling machine can realize the glue filling of irregular figures such as points, lines, arcs and circles.

产品特点 Product features

1. 通过精确控制计量马达，达到双组份胶水的精确配比、自动混合、自动定量出胶；
2. 具备真空上料、真空脱泡,可选配加热搅拌、自动清洗、压力监测等功能，能应对各种复杂的胶水环境；
3. 配胶准：高精密齿轮泵，充分发挥其优势，大胶量供胶、高比例胶量配比；
4. 配置泵体：齿轮泵、螺杆泵、柱塞泵；

1. Accurate proportioning, automatic mixing and automatic quantitative dispensing of two-component glue are achieved by accurately controlling the metering motor;
2. It has the functions of vacuum feeding and vacuum defoaming, optional heating and stirring, automatic cleaning, pressure monitoring, etc., and can cope with various complex glue environments;
3. Glue matching accuracy: high-precision gear pump, giving full play to its advantages, large glue supply and high proportion glue ratio;
4. Configure pump body: gear pump, screw pump and piston pump;



全自动灌胶机

All of automatic glue machine

型号: NS.GJ.771

产品特点

Product features

- 1.通过精确控制计量马达，达到双组份胶水的精确配比、自动混合、自动定量出胶。
- 2.具备真空上料、真空脱泡,可选配加热搅拌、自动清洗、压力监测等功能，能应对各种复杂的胶水环境。
- 3.操作系统稳定，操作界面友好，性价比高。
- 4.独有工交系统，清洗系统、真空泵、胶水过滤、压力检测可选配。

1. Accurate proportioning, automatic mixing and automatic quantitative dispensing of two-component glue are achieved by accurately controlling the metering motor.
2. It has the functions of vacuum feeding and vacuum defoaming, optional heating stirring, automatic cleaning, pressure monitoring, etc., and can cope with various glue environments.
3. Stable operating system, friendly interface and high cost performance.
4. Unique delivery system, cleaning system, vacuum pump, glue filtration and pressure detection can be selected.



自动灌胶机应用系列

应用行业

Application industry

无需专用治具,定位精度要求高的产品,各类双组份胶水,电(线)路板行业、电子元器件行业、电光源行业、小家电行业、点火器行业、车载用品行业、吸尘器行业、过滤器行业等众多领域;

适用胶水: 热熔胶、环氧ab胶、聚氨酯胶、硅胶、UV胶、水晶胶等;

Products that require high positioning accuracy without special fixture, all kinds of two-component glue, electric (wire) road board industry, electronic components industry, electric light source industry, small household appliances industry, igniter industry, vehicle supplies industry, vacuum cleaner industry, filter industry and many other fields; Applicable glue: hot melt adhesive, epoxy ab glue, polyurethane glue, silica gel, UV glue, crystal glue, etc.

技术参数 technical parameter

设备用途 Equipment use	产品自动灌胶 Automatic glue filling of products	
灌胶环境 Glue pouring environment	常压 ordinary pressure	
控制系统 control system	PLC+触摸屏 (三菱PLC+威纶触摸屏) PLC+Touch Screen (Mitsubishi PLC+Veyron Touch Screen)	
胶水类型 Glue type	聚氨酯、(有机硅、环氧树脂) Polyurethane, (silicone, epoxy resin)	
胶水比例 Glue ratio	1: 1~1: 10	
配比精度 Proportioning accuracy	±2%	
混胶方式 Rubber mixing mode	动态混合阀 Dynamic mixing valve	
胶罐容积 Rubber tank volume	A胶25L, B胶25L	
出胶速度 Glue outlet speed	1-15克/S	
气源 air supply	0.5-0.7 MPa以上;接管口径Φ8	
设备尺寸 Equipment size	1550*1150*1450mm	
功能描述 functional description	程序储存功能 Program storage function	设备可存储多组灌/点胶参数, 相同产品无需要重新编辑 参数及程序 The equipment can store multiple sets of pouring/dispensing parameters, and the same product re-edit the parameters and procedures.
	防固化功能 Anti-curing function	停机一段时间(自由设定)后自动启动防固化功能, 自动排少量胶水进接胶盒, 防止胶水固化; Automatically start the anti-curing function after stopping for a period of time (freely set), and automatically discharge a small amount of glue into the glue box to prevent the glue from curing;
	程序监控功能 Program monitoring function	程序进行实时监控A、B罐体真空脱泡, 自动搅拌, 罐体和管路配加热系统, 罐体存量等各项系统, 故障时设备能自动报警并把故障位置显示在操作界面上; The program monitors the vacuum defoaming and automatic stirring of tanks A and B in real time, and the tanks and pipelines are equipped with heating systems, tank stock and other systems. When there is a fault, display the fault position on the operation interface.

真空自动灌胶机

Vacuum automatic glue machine



产品特点

Product features

1. 定位准，精度高，运行误差小，采用双层线性滑轨和高精度平衡装置。
2. 可增加加热装置，配有A胶搅拌装备防止沉淀。配胶、灌胶一体化设计，随用随配，全自动操作。
3. 配胶准，多重过滤系统，清洗方便。
4. 配胶、灌胶一体化设计，随用随配，全自动操作。

1. Accurate positioning, high precision, small running error, double-layer linear slide rail and high-precision balancing device.
2. A heating device can be added, equipped with glue A stirring equipment to prevent precipitation. Glue mixing and filling are integrated, and it can be used with automatic operation.
3. Accurate glue distribution, multiple filtration system and convenient cleaning.
4. Integrated design of glue dispensing and pouring, with automatic operation.

技术参数 technical parameter

设备名称 device name	真空灌胶机 Vacuum glue filling machine
外形尺寸 outline dimension	500*500*150mm
运动行程 Motion stroke	500*500*150mm
配胶比例 Proportion of glue distribution	5: 1或1: 1或其它固定比例可调 5: 1 or 1: 1 or other fixed ratio can be adjusted.
抽真空装置 Vacuum pumping device	高级真空泵 Advanced vacuum pump
出胶流量 Glue discharge	1-5g/5s
输入气压 Input air pressure	高精密齿轮泵+螺杆泵 High precision gear pump+screw pump
编程方式 Programming mode	示教编程 Teaching programming
胶桶容量 Rubber bucket capacity	A/30L B/30L
主泵(A泵)/副泵(B泵) Main pump (a pump)/auxiliary pump (b pump)	3.2cc/转(体积)/1.2cc/转(体积)
额定电源功率 Rated power supply	AC220V 50Hz 1000W



设备名称：AB自动灌胶机

Equipment name: AB automatic glue machine.

产品特点 Product features

1. 按需配比-精确混合双组份AB胶按比例精确计量搅拌混合。
2. 持续供料-AB胶独立供胶实现胶水持续自动供胶，配备2个清洗桶，两组计量泵，AB胶分别独立储放和供胶。
3. 自动灌胶-精准走位将自动灌胶系统加载到四轴平台实现全自动灌胶，节省人力操作，灌胶效率更高。
4. 灌胶机需要满足UPH≥400pcs,故障率≤5%，设备点胶良率≥99.5%。

1. Proportioning according to demand-accurate mixing Two-component AB glue is accurately metered, stirred proportion.
2. Continuous feeding -AB glue is supplied independently to realize continuous and automatic glue supply. It is equipped with two cleaning barrels and two groups of metering pumps, and AB glue is stored and supplied independently.
3. Automatic glue filling-accurate positioning. Load the automatic glue filling system on the four-axis platform to realize automatic glue filling, which saves manpower operation and has higher glue filling efficiency.
4. Glue filling machine shall meet UPH≥400pcs, failure rate ≤ 5%, and equipment dispensing yield ≥ 99.5%.

参数规格 Parameter specification

设备名称 device name	AB自动灌胶机 AB automatic glue machine
外形尺寸 outline dimension	1500*1105*1850mm
运动行程 Motion stroke	500*500*100mm三轴运动平台 500*500*100mm triaxial motion platform
最大吐胶量 Maximum glue discharge	1-10g/s
吐胶精度 Glue ejection accuracy	胶量±2%,比例:±2% Glue content 2%, proportion: 2%
输入气压范围 Input air pressure range	0.4-0.8MPa
头部密封受压 Head seal compression	MAX≤2.6Mpa
胶量水粘度 Viscosity of glue and water	<10000CPS
操作方式 Mode of operation	自动 automatic
计量方式 Measurement mode	高精度螺杆泵+齿轮泵 High precision screw pump+gear pump
压力桶 Pressure barrel	25升
额定电源功率 Rated power supply	220V 50Hz 4.5kW

产品特点 Product features

1. 配胶准：高精度齿轮泵，充分发挥其优势，大胶量供胶、高比例胶量配比的全新技术突破。
2. 独创定时排胶系统：防止换班、休息时暂时停止灌胶，过了胶水操作时间，导致的搅拌系统胶水固化，无限延时操作时间。
3. 自动清洗系统：机器采用分液分装方式，只在出胶头处混合，用完后自动清洗，操作快速方便。
4. 配胶、灌胶一体化设计，随用随配，全自动操作。

1. Glue matching accuracy: high-precision gear pump, giving full play to its advantages, a brand-new technical large glue supply and high proportion glue ratio.
2. Original timing glue discharging system: to prevent glue pouring from temporarily stopping during shift change and rest, and the glue in the mixing system will solidify after the glue operation time, and the operation time delayed indefinitely.
3. Automatic cleaning system: The machine adopts liquid separation and sub-packaging, mixing only at outlet, and operate.
4. Integrated design of glue dispensing and pouring, with automatic operation.

参数规格 Product features

设备名称 device name	半自动灌胶机 Semi-automatic glue filling machine		
外形尺寸 outline dimension	950*650*1500mm		
灌胶速度 Pouring speed	5-15g可调（根据胶水特性有一定差异） 5-15g adjustable (there are some differences according t characteristics of glue)		
灌胶精度 Glue pouring accuracy	胶量±2%,比例:±2% Glue content 2%, proportion: 2%		
吐胶精度 Glue ejection accuracy	胶量±2%,比例:±2% Glue content 2%, proportion: 2%		
输入气压范围 Input air pressure range	0.4-0.8MPa		
头部密封受压 Head seal compression	MAX≤2.6Mpa		
胶量水粘度 Viscosity of glue and water	<10000CPS		
操作方式 Mode of operation	手动 manual		
胶量比例控制 Proportional control of glue content	高精度计量泵 High precision metering pump		
A/B胶桶容量 A/b rubber drum capacity	50L		
额定电源功率 Rated power supply	220V 50Hz 1000W	A/B泵	螺杆泵24CC/齿轮泵6CC Screw pump 24CC/ /gear pump 6CC



设备名称：半自动灌胶机

Name of equipment: semi-automatic glue filling machine

精密型点胶机—M/B系列

Precision dispensing machine-M/B series

钢型材点胶机器人

Steel profile dispensing robot

台面式平台移动系列，小巧的身材，多样化的应用工艺与模块

Table-top platform mobile series, compact figure, diversified application technology and modules

产品材质: Product material

使用铝型材材质,结构牢固,运行稳定,高速精准,具备高性价比的同时,也能满足多种点胶应用工艺;

The use of aluminum profiles has the advantages of firm structure, stable operation, high speed and accuracy, high cost performance, dispensing application processes;

B系列平台: B series platform:

三轴、四轴基础运动平台,视觉运动平台,可拓展五轴、六轴,多种点胶针头、针筒、点胶阀控制器,可配备多连式点胶单元;

Three-axis and four-axis basic motion platform and visual motion platform can expand five-axis and six-axis dispensing needles, syringes and dispensing valve controllers, and can be equipped with multi-connected dispensing units.

精密型B系列产品特点OL Precision B series product features OL

1.操作简单便利,高速精确(比同类产品精度高出一倍);

2.采用梯形加减速、速度前瞻、微线段插补等技术,可实现任意非平面的3D路径;

3.全面点胶工艺解决方案,包括提前关胶,滞后开胶,斜位上抬,运动中变速,封闭图形圈数设置等功能;

1, simple and convenient operation, high speed and accuracy (twice as high as that of similar products);

2. Any non-planar 3D path can be realized by using trapezoidal acceleration and deceleration, speed foresight and micro-line interpolation.

3. A comprehensive dispensing process solution, including the functions of closing the glue in advance, opening the glue later, lifting at an oblique position, changing speed during movement, setting the number of closed graphics laps, etc.



迷你型三轴点胶机—M系列

Mini three-axis dispensing machine-M series



产品介绍 Product introduction

- 台面式平台移动系列，小巧的身材，多样化的应用工艺与模块。
- 使用铝型材材质，结构牢固，运行稳定，高速精准，具备高性价比的同时，也能满足多种点胶应用工艺。
- B系列平台：三轴、四轴基础运动平台，视觉运动平台，可拓展五轴、六轴，多种点胶针头、针筒、点胶烟控制器，可配备多连式点胶单元。

Table-top platform mobile series, compact figure, diversified application technology and modules. Using aluminum profile material, it has firm structure, stable operation, high speed and accuracy, high cost performance, and can also meet a variety of dispensing application processes.

B-series platform: three-axis and four-axis basic motion platform, visual motion platform, which can expand five-axis and six-axis dispensing needles, needles and cigarette controllers, and can be equipped with multi-connected dispensing units.

精密型B系列产品特点OL Features of precision B series products OL

- 1.操作简单便利，高速精确(比同类产品精度高出一倍)；
- 2.采用梯形加减速、速度前瞻、微线段插补等技术，可实现任意非平面的3D路径；
- 3.全面点胶工艺解决方案，包括提前关胶，滞后开胶，斜位上抬，运动中变速，封闭图形圈数设置等功能；

1. Simple and convenient operation, high speed and accuracy (twice as high as that of similar products);
2. Using trapezoidal acceleration and deceleration, speed foresight, micro-line interpolation and other technologies, any non-planar 3D path can be realized;
3. A comprehensive dispensing process solution, including the functions of closing the glue in advance, opening the glue later, lifting at an oblique position, changing speed during movement, setting the number of closed graphics laps, etc.

可选配 Optional



CCD视觉辅助
CCD visual aid



PUR热熔胶
CPUR hot melt adhesive



AB点胶系统
AB system



胶阀/胶枪
Glue gun valve



精密螺杆阀
Screw valve

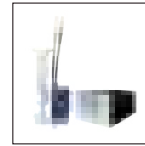

气动/压电喷射阀
Piezoelectric injection valve

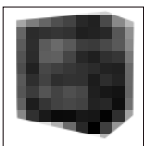

UV光源固化机
UV light source curing



自动对针装置
Automatic needle alignment

迷你点胶机—M系列参数

Mini dispensing machine-M series parameters

技术参数 technical parameter

<p>迷你型系列 Miniature series</p>			
<p>产品名称 product name</p>	<p>迷你型三轴点胶机 Miniature three-axis dispensing machine</p>	<p>迷你旗帜式三轴点胶机 Mini flag type three-axis dispensing machine</p>	<p>迷你型四轴点胶机—针头旋转式 Miniature four-axis dispensing machine-needle rotary type</p>
<p>产品型号 product model</p>	<p>NS.SP920MB/MF</p>	<p>NS.SP920MJ</p>	<p>NS.SP920MF-W2</p>
<p>平台移动速度类型 Platform moving speed type</p>	<p>X/Y轴0.1-500mm/S Z轴300mm/S</p>		
<p>运动范围行程 Range of motion stroke</p>	<p>(X) 200*(Y) 200* (Z) 80mm(行可定制)</p>	<p>(X) 200*(Y) 200*(z) 80mm(行程可定制)</p>	<p>(X) 200* (Y) 200* (Z) 80mmW2-360° (行程可定制)</p>
<p>重复精度 repeatability</p>	<p>±0.01mm</p>		
<p>内存存 Memory storage</p>	<p>超大容量高速文件存储器，可储存文件999个、每个56000点(可支持U盘COPY) Super-capacity high-speed file storage, which can store 999 files with 56,000 points each (supporting U disk COPY).</p>		
<p>I/O讯 I/O</p>	<p>4nputs</p>		
<p>输入电源 input power supply</p>	<p>AC110V/220V/50-60HZ 功率150W</p>		
<p>驱动方式 type of drive</p>	<p>日本微步进级精密马达 / 高精度马达系统 (可选配伺服系统) Japanese micro-stepping precision motor/high precision motor system (servo system can be selected)</p>		
<p>运动插补功能 Motion interpolation function</p>	<p>3D立体空间任意路线皆可 Any route in 3D space can be used.</p>		
<p>工作环境温度湿度 Working environment humidity</p>	<p>5-40°C/20-90%</p>		
<p>外形尺寸 outline dimension</p>	<p>L385*W300*H468mm /28KG</p>	<p>L365*W300*H520mm /35KG</p>	<p>L385*W300*H468mm /30KG</p>
<p>产品特点 Product features</p>	<p>1.操作简单便利、高速精确。(比同类产品精度高出1倍); 2.体积小、空间利用率高,实现小身材大作用; 3.可以配备多连式点胶单元; 4.全面点胶工艺解决方案,包括提前关胶,滞后开胶,斜位上抬,运动中变速封闭图形圈数设置等功能; 1. Simple and convenient operation, high speed and accuracy. (1 times higher than that of similar products); 2. Small size, high space utilization rate, realizing the function of small body and big body; 3. It can be equipped with a multi-connected dispensing unit; 4. A comprehensive dispensing process solution, including the functions of closing the glue in advance, opening the glue later, lifting at an oblique position, setting the number of closed graphics with variable speed during movement, etc.</p>	<p>1.悬臂式,灵活使用,可独立点胶,也可放置流水线使用不受影响,成本低操作简单; 2.镜面不锈钢材质,易保养,耐腐蚀; 3.体积小、空间利用率高,实现小身材大作用; 4.操作简单便利,高速精确; 1. Cantilever type, flexible to use, can dispense glue independently, and can also be placed in an assembly line for use without being affected, with low cost and simple operation; 2. Mirror stainless steel, easy to maintain and corrosion resistant; 3. Small size, high space utilization rate, realizing the function of small body and big body; 4. Simple and convenient operation, high speed and accuracy;</p>	<p>1.在三轴基础上增加一个轴,实现垂直面点胶角度可手动调节,覆盖直角死角点胶,特别适合小耳机打90度直角侧边胶; 2.体积小、空间利用率高,实现小身材大作用; 3.操作简单便利、高速精确。(比同类产品精度高出1倍); 4.全面点胶工艺解决方案,包括提前关胶,滞后开胶,斜位上抬,运动中变速封闭图形圈数设置等功能; 1. An additional shaft is added on the basis of three shafts, so that the glue dispensing angle on the vertical surface can be manually adjusted, covering the right-angle dead angle, to glue 90-degree right-angle side edges; 2. Small size, high space utilization rate, realizing the of small . 3. Simple and convenient operation, accuracy. (1 times higher than that of similar products); 4. A comprehensive dispensing process solution, functions of closing the glue in advance, opening the glue later, lifting at an position, setting the number of closed graphics during movement, etc.</p>

精密型点胶机—B系列

Precision dispensing machine-B series

技术参数 technical parameter

精密型系列 Precision series



产品名称 product name	精密型四轴点胶机 Precision four-axis dispensing machine	重载型三轴点胶机 Heavy-duty three-axis dispensing machine	精密型双Y四轴点胶机 Precision double y four-axis dispensing machine	精密型三轴点胶机 Precision three-axis dispensing machine
产品型号 product model	NS.SP.925B-W1	NS.SP.925B	NS.SP.930BF/940BF-Y	NS.SP.930BF/940BF
平台移动速度类型 Platform moving speed type	X/Y轴0.1-500mm/S Z轴300mm/S			X/Y轴0.1-500mm/S Z轴200mm/S
运动范围行程 Range of motion stroke	(X) 200* (Y) 250* (Z) 80mm	(X) 225* (Y) 200* (Z) 80mm	(X) 500* (Y) 300*300* (Z) 100mm (行程可定制)	(X) 300* (Y) 300* (Z) 100mm (行程可定制)
重复精度 repeatability	±0.01mm			
内存 Memory storage	超大容量高速文件存储器, 可储存文件999个、每个56000点(可支持U盘COPY) Super-capacity high-speed file storage, which can store 999 files with 56,000 points each (supporting U disk COPY).			
I/O讯	4nputs			
输入电源 Input power supply	AC110V/220V/50-60HZ 功率150W			
驱动方式 type of drive	日本微步进级精密马达 / 高精度马达系统 (可选配伺服系统) Japanese micro-stepping precision motor / high precision motor system (servo system can be selected)			
运动插补功能 Motion interpolation function	3D立体空间任意路线皆可 Any route in 3D space can be used.			
工作环境温度湿度 Working environment humidity	5-40°C/20-90%			
外形尺寸 outline dimension	L370*W495*H668mm 50KG	L 380*W 410*H510mm /28KG	L 725*W 685*H635mm /30KG	L513*W 484*H605mm /35KG

产品特点 Product features

<p>1.操作简单便利、高速精确。(比同类产品精度高出1倍);</p> <p>2.实现与PC联机调试功能,图形化的所见即得编程方式任意实现非平面3D路径;</p> <p>3.全面点胶工艺解决方案,包括提前关胶,滞后开胶,斜位上抬,运动中变速,封闭图形圈数设置等功能;</p> <p>1. Simple and convenient operation, high speed and accuracy. (1 times higher than that of similar products);</p> <p>2. Realize the online debugging function with PC, and realize the non-planar 3D path by graphical WYSIWYG programming;</p> <p>3. A comprehensive dispensing process solution, including the functions of closing the glue in advance, opening the glue later, lifting at an oblique position, ment, setting the number of closed graphics laps, etc.</p>	<p>1.采用梯形加减速、速度前瞻、微线段插补等技术可实现任意非平面的3D点路径;</p> <p>2.实现与pc联机调试等功能图形化的所见即所得编程方式;</p> <p>3.设有胶点及真空吸/吹功能,特别适合于手机喇叭,受话器,摄像头等产品胶水涂布,产品搬运;</p> <p>1. Any non-planar 3D point path can be realized by using trapezoidal acceleration and deceleration, speed foresight and micro-line interpolation.</p> <p>2. Realize the graphical WYSIWYG programming mode of online debugging with pc;</p> <p>3. It is equipped with some glue and vacuum suction/blowing function, which is especially suitable for glue coating and product handling of mobile phone speakers, receivers, cameras and other products;</p>	<p>1.双Y平台,交替作业,提高生产效率;</p> <p>2.操作简单便利、高速精确。(比同类产品精度高出1倍);</p> <p>3.全面点胶工艺解决方案,包括提前关胶,滞后开胶,斜位上抬,运动中变速,封闭图形圈数设置等功能;</p> <p>1. Double Y platform, alternating operation, improving production efficiency;</p> <p>2. Simple and convenient operation, high speed and accuracy. (1 times higher than that of similar products);</p> <p>3. A comprehensive dispensing process solution, including the functions of closing the glue in advance, opening the glue later, lifting at an oblique position, changing speed during movement, setting the number of closed graphics laps, etc.</p>	<p>1.适合尺寸大产品,三维校正,可任意实现非平面3D路径;</p> <p>2.操作简单便利、高速精确。(比同类产品精度高出1倍);</p> <p>3.全面点胶工艺解决方案,包括提前关胶,滞后开胶,斜位上抬,运动中变速,封闭图形圈数设置等功能;</p> <p>1. Suitable for large-size products, three-dimensional correction, and arbitrary realization of non-planar 3D paths;</p> <p>2. Simple and convenient operation, high speed and accuracy. (1 times higher than that of similar products);</p> <p>3. A comprehensive dispensing process solution, including the functions of closing the glue in advance, opening the glue later, lifting at an oblique position, changing speed during movement, setting the number of closed graphics laps, etc.</p>
---------------------------------------------------------------------------------------------------------------------------------------------------------------------------------------------------------------------------------------------------------------------------------------------------------------------------------------------------------------------------------------------------------------------------------------------------------------------------------------------------------------------------------------------------------------------------------------------------------------------------	--------------------------------------------------------------------------------------------------------------------------------------------------------------------------------------------------------------------------------------------------------------------------------------------------------------------------------------------------------------------------------------------------------------------------------------------------------------------------------------------------------------------------------------------------------------------------------------------------------	-----------------------------------------------------------------------------------------------------------------------------------------------------------------------------------------------------------------------------------------------------------------------------------------------------------------------------------------------------------------------------------------------------------------------------------------------------------------------------------------------------------------------------------------------------------------------------------------	-----------------------------------------------------------------------------------------------------------------------------------------------------------------------------------------------------------------------------------------------------------------------------------------------------------------------------------------------------------------------------------------------------------------------------------------------------------------------------------------------------------------------------------------------------------------------------------------------------------------------------------------

高精度型点胶机—H系列

High precision dispensing machine-H series

钢材型点胶机器人

Steel dispensing robot



台面式点胶机系列

产品介绍 Product introduction

- 强大的系统功能，实现更高端的自动化点胶应用工艺。
- 使用钢材材质，结构牢固，运行稳定，高速精准，具备高性价比的同时，也能满足多种点胶应用工艺。

Powerful system functions to realize higher-end automatic dispensing application process. Using steel profile material, it has firm structure, stable operation, high speed and accuracy, high cost performance, and can also meet a variety of dispensing application processes.

精密型H系列产品特点OL Features of precision H series products OL

- 1.采用高精度伺服马达+研磨滚珠丝杠，更高精度，更大负载，更丰富的扩展应用。
- 2.H系列点胶平台有着更为先进与强大的功能，可搭载视觉定位，自动校正、点胶检测、激光测高与补偿、产品信息扫描，MES系统对接、安全上罩、安全光栅、隔音罩、喷嘴清洁、胶量称重等功能，满足各个行业与场景的使用。
- 3.可搭配自主核心的喷射阀、控制器、实现流体的高精度稳定吐出和轨迹精确控制。

1. Adopt high-precision servo motor+grinding ball screw, with higher precision, greater load and richer expanded application.
- 2.H series dispensing platform has more advanced and powerful functions, which can be equipped with visual positioning, automatic calibration, dispensing detection, laser height measurement and compensation, product information scanning, MES system docking, safety cover, safety grating, sound insulation cover, nozzle cleaning, glue quantity weighing and other functions to meet the needs of various industries and scenes.
3. It can be matched with the injection valve and controller with independent core to realize high-precision stable ejection of fluid and precise trajectory control.

基础配置HE系列 Basic configuration HE series

- 三轴运动平台 Three-axis motion platform
- 视觉系统 visual system
- 清胶校准模块 Glue cleaning calibration module
- 针筒阀 Needle simple valve

可选配 Optional



CCD视觉辅助
CCD visual aid



PUR热熔胶
CPUR hot melt adhesive



AB点胶系统
AB system



胶阀/胶枪
Glue gun valve



精密螺杆阀
Screw valve

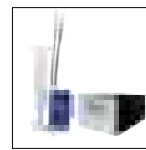

气动/压电喷射阀
Piezoelectric injection valve

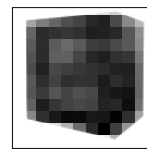

UV光源固化机
UV light source curing



自动对针装置
Automatic needle alignment

技术参数 technical parameter

迷你型系列 Miniature series

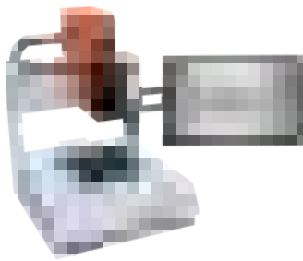

产品名称 product name	三轴丝杆点胶机 Three-axis screw dispensing machine	三轴精密视觉点胶机 Three-axis precision vision dispensing machine	高精度双Y四轴点胶机—视觉款 High-precision double Y four-axis dispensing machine—visual model
产品型号 product model	NS.SP.920H/930H	NS.SP.920HE/930HE	NSSP.930H-Y/940HE-Y
平台移动速度类型 Platform moving speed type	X/Y轴0.1-500mm/S Z轴300mm/S	X/Y轴0.1-300mm/S Z轴0.1-200mm/S	(X)0.1-400/(Z)300mm/s
运动范围行程 Range of motion stroke	(X) 200*(Y) 200*(Z) 100mm(行程可定制)	(X) 200*(Y) 200*(Z) 100mm(行程可定制)	(X)400(Y)1Y2)300(Z)100mm/s (行程可定制)
重复精度 repeatability	±0.01mm		
内存 Memory storage	超大容量高速文件存储器, 可储存文件999个、每个56000点(可支持U盘COPY) Super-capacity high-speed file storage, which can store 999 files with 56,000 points each (supporting U disk COPY).		
I/O	4nputs		
输入电源 Memory storage	AC110V/220V/50-60HZ 功率:500W		AC110V/220V(内部切换)50-60HZ /功率:800W
驱动方式 type of drive	高精度伺服步进马达 High precision servo stepping motor		
视觉定位系统 Visual positioning system	无 without	标配高像素工业相机 High-pixel industrial cameras are standard.	
视觉分辨率 Visual resolution	无 without	0.01*0.01mm/Pixel(可调)	
识别范围 Recognition range	无 without	14*14mm	
运动插补功能 Motion interpolation function	3D立体空间任意路线皆可 Any route in 3D space can be used.		
工作环境温度湿度 Working environment humidity	5-40°C/20-90%		
外形尺寸 outline dimension	L645*W 625*H700mm /约45KG	L485*W395*H561mm /约55KG	L590*W520*H660mm /约55KG
产品特点 Product features	<p>1.小巧的身材, 丰富的应用; 2.采用高精度伺服马达+研磨滚珠丝杆, 更高的精度, 更丰富的拓展应用; 3.丰富的产品种类, 行程可选, 满足不同产品的应用; 4.可搭载自主核心的气动控制器或喷射阀, 实现流体的高精度稳定吐出和轨迹精确的控制非接触式;</p> <p>1. Small body and rich applications; 2. Adopt high-precision servo motor+grinding ball screw, with higher precision and richer expansion and application; 3. Rich product types and optional itinerary to meet the application of different products; 4. It can be equipped with pneumatic controller or injection valve with independent core to realize high-precision and stable ejection of fluid and precise control of trajectory in a non-contact way;</p>	<p>1.智能视觉点胶系统, 配合MARK 拍照实时定位纠正点胶轨迹, 引导点胶; 2.满足窄边框和狭小空间点胶; 3.搭载喷射阀功能模块, 非接触点胶, 实现更小的点胶直径, 也可搭载其他点胶阀方式, 以及更广的适用领域4可实现0.25mm的稳定胶线宽或胶点直径;</p> <p>1. Intelligent vision dispensing system, which coordinates with MARK to take photos, position and correct dispensing trajectory in real time, and guide dispensing; 2. Meet the requirements of dispensing glue in narrow borders and narrow spaces; 3. Equipped with injection valve function module, non-contact dispensing can realize smaller dispensing diameter, and can also be equipped with other dispensing valves, as well as a wider application field. 4. Stable dispensing line width or dispensing point diameter of 0.25mm can be realized;</p>	<p>1.点胶倒计时、测高功能、针头自动清洗 2.冷却恒温数显, 挤胶压力显示报警; 3.拥有胶水保护套, 防止爆管伤人, 挤胶压力报警信号;4.采用智能视觉点胶系统, MARK拍照实时定位纠正点胶轨迹, 引导点胶;</p> <p>1. Intelligent vision dispensing system, which coordinates with MARK to take photos, position and correct dispensing trajectory in real time, and guide dispensing; 2. Meet the requirements of dispensing glue in narrow borders and narrow spaces; 3. Equipped with injection valve function module, non-contact dispensing can realize smaller dispensing diameter, and can also be equipped with other dispensing valves, as well as a wider application field. 4. Stable dispensing line width or dispensing point diameter of 0.25mm can be realized;</p>

五轴四联动精密点胶机—视觉款

Five-axis four-linkage precision dispensing machine-visual model

■ 多姿态点胶轨迹联动 Multi-pose dispensing trajectory linkage

型号: NS.SP431HE-AV



基础配置 Basic configuration

- 三轴运动平台 Three-axis motion platform
- 视觉系统 visual system
- 清胶校准模块 Glue cleaning calibration module
- 针筒阀 Needle simple valve

可选配 Optional

高灵活性: 可配各种阀体, 如喷射阀、压电阀、针对客户需求, 灵活选用; 各类功能模块高度集成, 可进行选配。
High flexibility: it can be equipped with various valve bodies, such as injection valve and piezoelectric valve, which can be flexibly selected according to customer needs; Various functional modules are highly integrated and can be selected.

- 针头校正 Needle calibration
- 液位检测 Liquid level detection
- 胶量称重 Glue weighing
- 点胶检测 Dispensing detection
- 激光测高 Laser altimetry
- 信息扫描 Needle valve
- 隔音罩 soundproof shade
- 安全上罩 Safety upper cover
- 安全光栅 Safety grating
- 喷胶清洁 Glue spraying cleaning

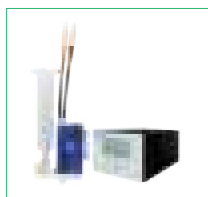

压电喷射阀
Piezoelectric injection valve

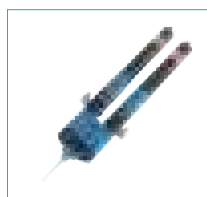

精密螺杆阀
Precision screw valve



AB挤胶系统
AB extrusion system

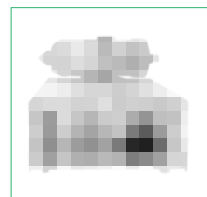

热熔胶针筒控制器
Hot melt adhesive syringe controller

技术参数 technical parameter

产品名称 product name	五轴四联动精密点胶机—视觉款 Five-axis four-linkage precision dispensing machine-visual model
产品型号 product model	NS.SP.431HE-AV
运动范围 Range of motion	(X/Y/Z/A/V轴) 400/300/100mm/360°/360°
最大负载 maximum load	(Y/Z轴) 10KG/5KG
移动速度 rate of travel	(X/Y轴) 0.1-800mm/S、(Z轴) 300mm/S
重复精度 repeatability	±0.01mm
储存内存 Storage memory	64G超大容量高速固态硬盘文件存储器(可定制120G) 64G ultra-large capacity high-speed fixed disk file storage (120G can be customized)
驱动方式 type of drive	高精度交流伺服系统 (最高配24位编码器) High precision AC servo system (up to 24-bit encoder)
传动方式 Transmission mode	静音丝杠精密模组 (研磨级) Silent lead screw precision module (grinding stage)
视觉定位系统 Visual positioning system	标配高像素工业相机 High-pixel industrial cameras are standard.
视觉分辨率 Visual resolution	0.01*0.01mm/Pixel(可调)
编程模式 Programming mode	键鼠+显示器 Keymouse+display
识别范围 Recognition range	14*14mm
输入电源 Input power supply	AC 110V/220V(内部切换) 50-60HZ
工作环境温度湿度 Working environment temperature and humidity	5-40°C/20-90% 不结露
外形尺寸 outline dimension	L604*W669*H775mm / 约80KG

高精度三轴丝杆点胶机—高速版

High precision three-axis screw dispensing machine-high speed version

型号: NS.SP.930HHE



产品特点 Product features

1. 不锈钢外壳，满足洁净要求；
 2. 智能视觉点胶系统，配合MARK拍照实时定位纠正点胶轨迹，引导点胶；
 3. 搭载喷射阀功能模块，非接触式点胶，实现更小的点胶直径，也可搭载其他点胶阀方式，以及更广的适用领域；
 4. 全面点胶工艺解决方案，包括提前关胶、滞后开胶、斜位上台、运动中变速、封闭图形圈数设置等功能；
1. Stainless steel shell, meeting the requirements of cleanliness;
2. Intelligent vision dispensing system, which coordinates with MARK to take photos, position and correct dispensing trajectory in real time, and guide dispensing;
3. Equipped with injection valve function module and non-contact dispensing to realize smaller dispensing diameter, and can also be equipped with other dispensing fields;
4. Comprehensive dispensing process solution, including the functions of closing the glue in advance, opening the glue later, coming to the stage obliquely, changing speed during movement, setting the number of closed graphics laps, etc.

基础配置 Basic configuration

- 三轴运动平台 Three-axis motion platform
- 视觉系统 visual system
- 清胶校准模块 Glue cleaning calibration module
- 针筒阀 Needle valve

可选配 Optional

高灵活性：可配各种阀体，如喷射阀、压电阀、针对客户需求，灵活选用；各类功能模块高度集成，可进行选配。

High flexibility: it can be equipped with various valve bodies, such as injection valve and piezoelectric valve, which can be flexibly selected according to customer needs; Various functional modules are highly integrated and can be selected.

- 针头校正 Needle calibration
- 液位检测 Liquid level detection
- 胶量称重 Glue weighing
- 点胶检测 Dispensing detection
- 激光测高 Laser altimetry
- 信息扫描 Needle valve
- 隔音罩 soundproof shade
- 安全上罩 Safety upper cover
- 安全光栅 Safety grating
- 喷胶清洁 Glue spraying cleaning

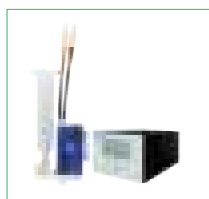

压电喷射阀
Piezoelectric injection valve

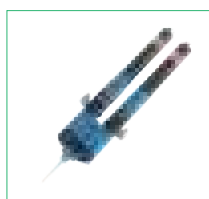

精密螺杆阀
Precision screw valve



AB挤胶系统
AB extrusion system

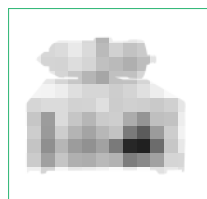

热熔胶针筒控制器
Hot melt adhesive syringe controller

技术参数 technical parameter

产品名称 product name	高精度三轴丝杆点胶机—高速版 High precision three-axis screw dispensing machine-high speed version
产品型号 product model	NS.SP930HHE
运动范围 Range of motion	(X/Y/Z轴)300/300/100mm
最大负载 maximum load	(Y/Z轴)20Kg/15Kg (最高速度不能最高负载) (Y/Z axis) 20Kg / 15Kg (maximum speed cannot be maximum load)
移动速度 rate of travel	(XY轴)0.1-800mm/s(Z轴)01-300mm/s
重复精度 repeatability	±0.01mm
储存内存 Storage memory	64G超大容量高速固态硬盘文件存储器(可定制120G) 64G ultra-large capacity high-speed fixed disk file storage (120G can be customized)
驱动方式 type of drive	高精度马达系统 (可选配伺服系统) High precision motor system (optional servo system)
传动方式 Transmission mode	精密丝杠模组 Precision screw module
视觉定位系统 Visual positioning system	标配高像素工业相机 High-pixel industrial cameras are standard.
视觉分辨率 Visual resolution	0.01*0.01mm/Pixel(可调)
编程模式 Programming mode	键鼠+显示器 Keymouse+display
识别范围 Recognition range	14*14mm
输入电源 Input power supply	AC110V/220V(内部切换)50-60HZ/功率:1500W
工作环境温度湿度 Working environment humidity	5-40°C/20-90%
外形尺寸 outline dimension	L590*W520*H660mm /约55KG

延伸系列应用

Extended series application

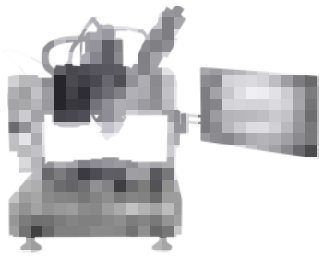
延伸系列 Extended series		
产品名称 product name	伺服压胶 Servo glue pressing	半封闭式 semienclosed
产品特点 Product features	<ol style="list-style-type: none"> 1.点胶倒计时、测高功能、针头自动清洗; 2.冷却恒温数显, 挤胶压力显示报警; 3.拥有胶水保护套, 防止爆管伤人, 挤胶压力报警信号; 4.采用只智能视觉点胶系统, MARK拍照实时定位纠正点胶轨迹, 引导点胶; <p>1. countdown to dispensing, height measurement function and automatic needle cleaning;</p> <p>2. Digital display of cooling constant temperature, display of extrusion pressure and alarm;</p> <p>3. Have a glue protective sleeve to prevent people from being injured by tube and give an alarm signal of glue squeezing pressure;</p> <p>4. Using an intelligent vision dispensing system, MARK takes photos to position and correct the dispensing trajectory in real time and guide the dispensing;</p>	<ol style="list-style-type: none"> 1.自动快速捕捉Mark定位, 对产品轮廓进行搜索识别, 自动校正补偿保证点胶位置精准; 2.各个轴的行程、运动速度和加速度, 均可按要求定制; 3.搭载喷射阀/螺杆阀功能模块, 非接触式点胶, 实现更小的点胶直径也可搭载其他点胶阀方式, 以及更广的适用领域; 4.采用伺服电机和研磨丝杠模组, 保证系统运行高精度、高速度、高效率高一一致性平台重复定位精度可达0.01mm; <p>1. Automatically and quickly capture Mark positioning, search and identify product contours, and automatically correct and compensate to ensure accurate dispensing position;</p> <p>2. The travel, movement speed and acceleration of each axis can be customized as required;</p> <p>3. Equipped with injection valve/screw valve function module, non-contact dispensing, valve modes, and wider application fields;</p> <p>4. The servo motor and grinding screw module are adopted to ensure the high precision, high speed, high efficiency and high consistency of the system, and the repeated positioning accuracy of the platform can reach 0.01mm;</p>

非接触式压电喷射阀 NS.PV.3200A系列

Non-contact piezoelectric injection valve NS.PV.3200A series

采用快拆式喷嘴设计，具备矫正功能，保证机械位置一致性
Adopt quick-release nozzle design, which has correction function and ensures the consistency of mechanical position.

产品参数 Product parameters >>

NS.PV.3200A		
喷射频率	Injection frequency	≤500Hz
最小喷射量	Minimum injection quantity	1nL
喷射精度	Injection accuracy	1%
矫正方式	Correction mode	底部螺母矫正 Bottom nut correction
适应粘度	Adaptive viscosity	1-500000mPa.s
加热温度	Heating temperature	≤220°C
气压	atmospheric pressure	≤5bar
电源	Power Supply	220V 50Hz
流体槽结构	Fluid tank structure	螺丝固定方式 Screw fixing method
外形尺寸	outline dimension	76*41*16mm

适配控制器 Adaptive controller >>



NS.PS.3200A 控制器

适用胶水 Suitable glue >>

- 可喷射热熔胶，环氧树脂、UV胶、油墨、SMT红胶、银浆、油脂、Underfill、Tuffy蓝胶等。
Can spray hot melt adhesive, epoxy resin, UV glue, ink, SMT red glue, silver paste, grease, Underfill, Tuffy blue glue, etc.

应用领域 application area >>

- 电子产品的外框粘接、摄像头模组、屏幕模组、FPC包封、底部填充、服装内衣等
External frame bonding of electronic products, camera module, screen module, FPC encapsulation, bottom filling, clothing and underwear, etc.



产品特点 Product features

- 耗材少，维护保养便捷，价格经济；
- 高速喷射，最大喷射速度500Hz/秒；
- 高精度始终保持胶点尺寸大小的一致性；
- 采用快拆式喷嘴设计，具备矫正功能，保证机械位置一致性；
- 压电陶瓷使用寿命长，使用成本低；
- 非接触式点胶，无需精确的定位Z轴高度；
- 超薄的阀体厚度，可满足点胶机双阀和多阀安装；

产品特点 Product features

- Less consumables, convenient maintenance and economical price;
- High-speed injection, the maximum injection speed is 500Hz / s;
- High precision always keeps the consistency of glue point size;
- Adopt quick-release nozzle design, with correction function, to ensure the consistency of mechanical position;
- Piezoelectric ceramics have long service life and low use cost;
- Non-contact dispensing, no need to accurately locate the height of Z axis;
- Ultra-thin valve body thickness can meet the installation of double valves and multiple valves of dispensing machine;

非接触式压电喷射阀控制器 NS.PS.3200A系列

Non-contact piezoelectric injection valve controller NS.PS.3200A series

功能强大，稳定可靠，操作简单方便。经过抗干扰及老化测试，保证控制器的稳定性

Powerful, stable and reliable, simple and convenient to operate. The anti-interference and aging tests ensure the stability of the controller.



产品参数 Product parameters >>

NS.PS.3200A控制器

外形尺寸 outline dimension	运行模式 operational mode	参数储存 Parameter storage	加热功能 Heating function	电源 Power Supply 	适配阀体型号 Adapted valve body model
245*142*142mm	单点模式 Single point mode	内部储存10组 Internal storage 10 groups	自带双通道加热功能 With dual-channel function.	220V AC,300W	NS.PV.2000A/NS.PV.2000B
	无限模式 Infinite mode	外部储存无限 External storage is infinite	可选配加热装置 Optional heating device		

适配阀体示意图>>

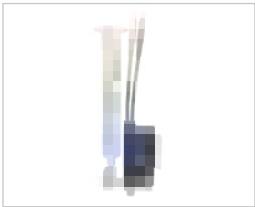

冷胶压电喷射阀50CC
Cold glue piezoelectric injection valve 50CC



加热桶30CC
Heating barrel 30CC

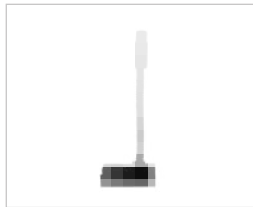

加热块
Heating block

产品特点 Product features

- 可精准控制驱动模块的打开、关闭、行程、时间的脉冲控制；
- 采用按键屏，界面简洁易懂，可根据需求输入多个控制器参数对工作过程精准配置；
- 控制器及驱动模块内置计数器功能，实时监控使用寿命；
- 内建232接口，可与上位机自由通讯，点胶状态获取及参数调整可由上位机执行；
- 配方功能，可通过外部I/O调用；
- 内置一组温控功能，可根据实际需求配置；
- 运行模式多样化，灵活可靠，满足各种个性化需求；

产品特点 Product features

- Pulse control of opening, closing, stroke and time of the driving module can be accurately controlled;
- Using the key screen, the interface is simple and easy to understand, and multiple parameters can be input according to the requirements to accurately configure working process;
- The controller and drive module have built-in counter function to monitor the service life in real time;
- Built-in 232 interface can communicate freely with the upper computer, and the dispensing state acquisition and parameter adjustment can be performed by the upper computer;
- Formula function, which can be called by external I/O;
- Built-in a set of temperature control functions, which can be configured according to actual needs;
- The operation mode is diversified, flexible and reliable, and meets various personalized needs;

非接触式压电喷射阀 NS.PV.3200A热胶系列

Non-contact piezoelectric injection valve NS.PV.3200A hot glue series

采用快拆式喷嘴设计，具备矫正功能，保证机械位置一致性

Adopt quick-release nozzle design, which has correction function and ensures the consistency of mechanical position.

产品参数 Product parameters >>

NS.PV.3200A		
喷射频率	Injection frequency	≤500Hz
最小喷射量	Minimum injection quantity	1nL
喷射精度	Injection accuracy	1%
矫正方式	Correction mode	底部螺母矫正 Bottom nut correction
适应粘度	Adaptive viscosity	1-500000mPa.s
加热温度	Heating temperature	≤220°C
气压	atmospheric pressure	≤5bar
电源	Power Supply	220V 50Hz
流体槽结构	Fluid tank structure	螺丝固定方式 Screw fixing method
外形尺寸	outline dimension	76*41*16mm



适配控制器 Adaptive controller >>



NS.PS.PTC-2两路温控器

适用胶水 Suitable glue >>

- 可喷射热熔胶，环氧树脂、UV胶、油墨、SMT红胶、银浆、油脂、Underfill、Tuffly蓝胶等。
Can spray hot melt adhesive, epoxy resin, UV glue, ink, SMT red glue, silver paste, grease, Underfill, Tuffly blue glue, etc.

应用领域 application area >>

- 电子产品的外框粘接、摄像头模组、屏幕模组、FPC包封、底部填充、服装内衣等
External frame bonding of electronic products, camera module, screen module, FPC encapsulation, bottom filling, clothing and underwear, etc.

产品特点 Product features

耗材少，维护保养便捷，价格经济；
高速喷射，最大喷射速度500Hz/秒；
高精度始终保持胶点尺寸大小的一致性；
采用快拆式喷嘴设计，具备矫正功能，保证机械位置一致性；
压电陶瓷使用寿命长，使用成本低；
非接触式点胶，无需精确的定位Z轴高度；
超薄的阀体厚度，可满足点胶机双阀和多阀安装；

产品特点 Product features

- Less consumables, convenient maintenance and economical price;
- High-speed injection, the maximum injection speed is 500Hz / s;
- High precision always keeps the consistency of glue point size;
- Adopt quick-release nozzle design, with correction function, to ensure the consistency of mechanical position;
- Piezoelectric ceramics have long service life and low use cost;
- Non-contact dispensing, no need to accurately locate the height of Z axis;
- Ultra-thin valve body thickness can meet the installation of double valves and multiple valves of dispensing machine;

非接触式压电喷射阀控制器 NS.PS.PTC-2两路温控器

Non-contact piezoelectric injection valve controller NS.PS.PTC-2 two-way thermostat

独立温度控制，更精准，更安全

Independent temperature control, more accurate and safer



产品参数 Product parameters >>

NS.PS.PTC-2两路温控器

外形尺寸 outline dimension	模块配置 Module configuration	最高温度 maximum temperature	电源 Power Supply 	温控精度 Temperature control accuracy
235*160*120mm	胶桶加热24VDC 150W Rubber bucket heating 24VDC 150W W.	200°C	220V AC,250W	误差+/-2°C Error+/-2°C
	喷嘴加热24VDC 50W Nozzle heating 24VDC 50W			

适配阀体示意图 Schematic diagram of adapter valve body >>

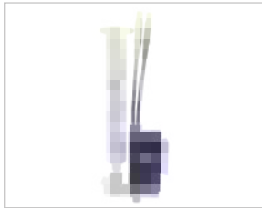

NS.PV.3200A



热胶压电喷射阀30CC
Hot glue piezoelectric injection valve 30CC



加热桶30CC
Heating barrel 30CC

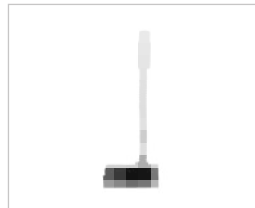

加热块
Heating block

产品特点 Product features

- 两路欧姆龙温度控制器；
- 控制温度精准，内置PID恒温控制；
- 自带存储；
- RS485通讯远程控制；
- 高精度铂电阻测温；
- 总加热功率250W，单路可达150W；

产品特点 Product features

- Two Omron temperature controllers;
- Accurate temperature control, built-in PID constant temperature control;
- Self-contained storage;
- RS485 communication remote control;
- High precision platinum resistance temperature measurement;
- The total heating power is 250W, and the single channel can reach 150 W;

耗材配件规格选择表: Specification selection table of consumable parts:

撞针: 采用高耐磨材料进行精密加工,规格丰富, 可用于压电喷射阀;

Firing pin: precision machining with high wear-resistant materials, with rich specifications, can be used for piezoelectric injection valves;

喷嘴: 采用高耐磨材料进行精密加工,规格丰富, 光泽度高;

Nozzle: high wear-resistant materials are used for precision machining, with rich specifications and high gloss;

 <p>压电撞针 Piezoelectric firing pin</p>	DD.03.00.0103-60	压电撞针	SR0.35撞针,R0.5-57 压电撞针	钨钢
	DD.08.00.0007-89	压电撞针	SR0.5撞针,R0.5-57 压电撞针	钨钢
	DD.03.00.0103-06	压电撞针	SR0.75撞针,R0.75-56.6 /钨钢	钨钢
	DD.03.00.0103-08	压电撞针	SR1.0撞针,R1.0-56.6 压电撞针	钨钢
	DD.03.00.0103-30	压电撞针	SR1.25撞针,R1.25-56.6 压电撞针	钨钢
	DD.03.00.0103-05	压电撞针	SR1.5撞针,R1.5-56.6 压电撞针	钨钢
	DD.08.00.0007-22	压电撞针	SR2.0撞针,R2.0-56.6 压电撞针	钨钢
	DD.03.00.0103-23	压电撞针	SR2.5撞针,R2.5-56.6 压电撞针	钨钢
	DD.03.00.0103-34	压电撞针	SR1.0撞针 (加长10mm) R1.0-66.1 压电撞针	钨钢
	DD.03.00.0103-37	压电撞针	SR1.5撞针,R1.5-56.6 压电撞针	钨钢
	DD.03.00.0103-50	压电撞针	SR2.0撞针,R2.0-56.6 压电撞针	钨钢
	DD.03.00.0103-56	压电撞针	SR1.0撞针,R1.0-71 压电撞针	钨钢
	DD.03.00.0103-58	压电撞针	SR1.0撞针 (加长15mm) R1.0-69.4 压电撞针	钨钢

 <p>压电喷嘴 Piezoelectric nozzle</p>	DD.03.00.0103-41	压电喷嘴	0.03喷嘴 (常规) 6-2.5-0.03 压电喷嘴	钨钢
	DD.03.00.0103-21	压电喷嘴	0.05喷嘴 (常规) 6-2.5-0.06 压电喷嘴	钨钢
	DD.03.00.0103-22	压电喷嘴	0.07喷嘴 (常规) 6-2.5-0.07 压电喷嘴	钨钢
	DD.03.00.0008-70	压电喷嘴	0.075喷嘴 (常规) 6-2.5-0.075 压电喷嘴	钨钢
	DD.03.00.0103-31	压电喷嘴	0.08喷嘴 (常规) 6-2.5-0.08 压电喷嘴	钨钢
	DD.03.00.0103-07	压电喷嘴	0.1喷嘴 (常规) 6-2.5-0.1 压电喷嘴	钨钢
	DD.03.00.0103-12	压电喷嘴	0.15喷嘴 (常规) 6-2.5-0.15 压电喷嘴	钨钢
	DD.03.00.0103-19	压电喷嘴	0.2喷嘴 (常规) 6-2.5-0.2 压电喷嘴	钨钢
	DD.08.00.0007-90	压电喷嘴	0.25喷嘴 (常规) 6-2.5-0.25 压电喷嘴	钨钢
	DD.08.00.0007-91	压电喷嘴	0.3喷嘴 (常规) 6-2.5-0.3 压电喷嘴	钨钢
	DD.08.00.0007-63	压电喷嘴	0.42喷嘴 (常规) 6-2.5-0.42 压电喷嘴	钨钢
	DD.03.00.0103-20	压电喷嘴	0.45喷嘴 (常规) 6-2.5-0.45 压电喷嘴	钨钢
	DD.03.00.0539-00	压电喷嘴	0.6喷嘴 (常规) 6-2.5-0.6 压电喷嘴	钨钢
	DD.03.00.0539-01	压电喷嘴	0.7喷嘴 (常规) 6-2.5-0.7 压电喷嘴	钨钢
	DD.03.00.0539-02	压电喷嘴	0.8喷嘴 (常规) 6-2.5-0.8 压电喷嘴	钨钢
 <p>压电尖喷嘴 Piezoelectric tip nozzle</p>	DD.08.00.0007-64	压电尖喷嘴	0.075喷嘴 (加长3MM) 6-5.5-0.075 压电喷嘴	钨钢
	DD.08.00.0007-66	压电尖喷嘴	0.15喷嘴 (加长3MM) 6-5.5-0.15 压电喷嘴	钨钢
	DD.08.00.0009-20	压电尖喷嘴	0.2喷嘴 (加长3MM) 6-5.5-0.2 压电喷嘴	钨钢
	DD.03.00.0103-27	压电尖喷嘴	0.1喷嘴 (加长3mm)6-5.5-0.1 压电喷嘴	钨钢
	DD.03.00.0103-28	压电尖喷嘴	0.1喷嘴 (加长5mm)6-7.5-0.1 压电喷嘴	钨钢

进口喷雾/点胶阀系列

Imported spray/dispensing valve series

专注精密流体控制经验十几年+

More than ten years experience in precision fluid control+

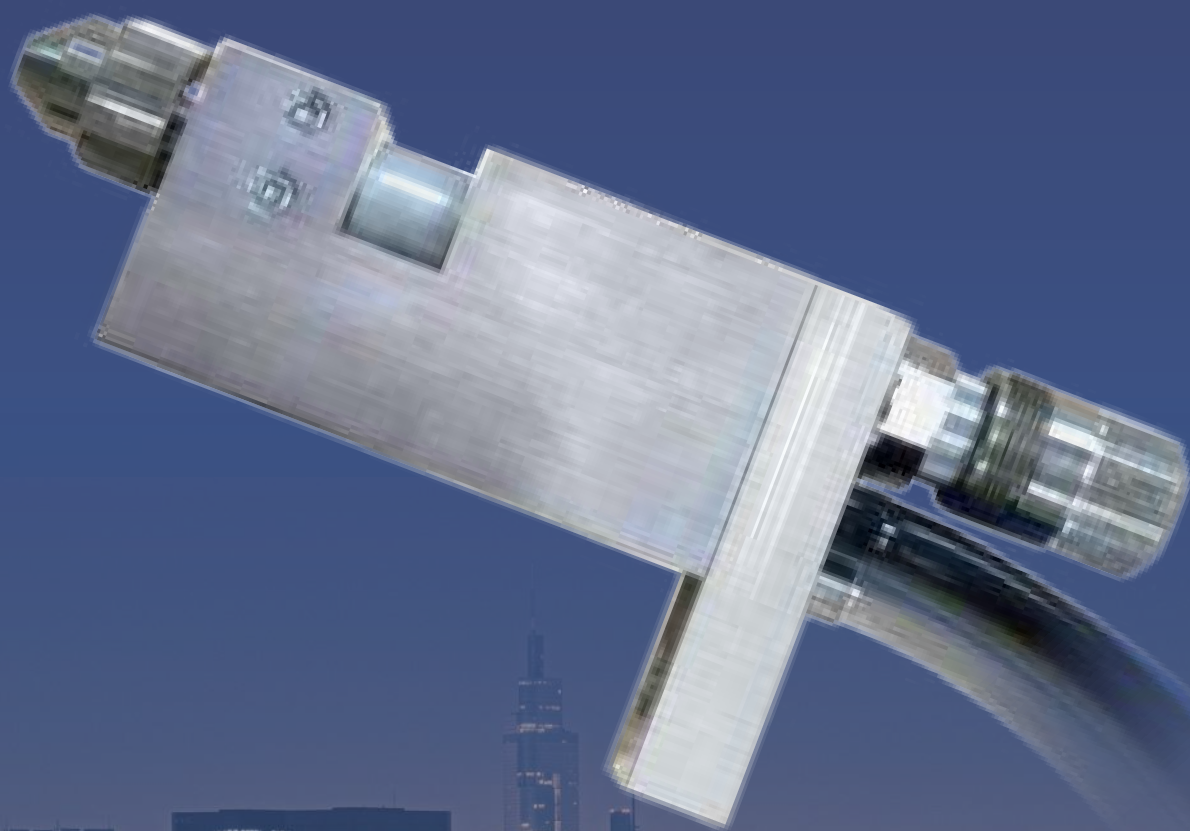

德国原装进口喷雾阀/刮胶阀系列
Germany imported spray valve/rubber scraping valve series.



型号: NS .PWF

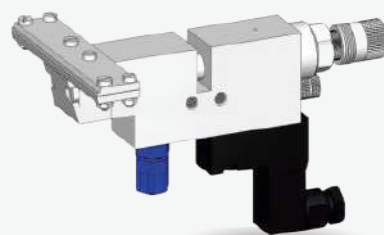

型号: NS .GJF.01

产品介绍 Product introduction

1.PWF解决普通喷枪所不能达到的特殊效果。它是一款顶级外控喷枪，以先进的设计、精良的制造、特殊的喷涂效果、耐用的品质。

2.GJF是一种气动控制的刮胶阀，用于刮涂高粘度胶水，可连续或间断刮胶。

1.PWF solves the special effects that ordinary spray guns can't achieve. It is a top-class external control spray gun with advanced design, excellent manufacturing, special spraying effect and durable quality.

2.GJF is a pneumatic control rubber scraping valve, which is used to scrape high-viscosity glue, and can scrape glue continuously or intermittently.

产品特点 Product features

- 1.枪身材质耐腐蚀铜镀镍,喷嘴与枪针进口316不锈钢材质,使用寿命长,磨损小;
- 2.喷嘴、空气帽有特氟龙材质可选,更耐腐蚀,寿命更长;
- 3.枪身内部特殊的空气结构,拥有快速开关枪的反应速度(0.1秒开/关);
- 4.口径:0.2、0.3、0.5、0.8、1.0、1.2、1.5、2.0mm;
- 5.外部控制特色:流量可以调节、雾化可以调节;6.低压高雾化喷枪(0.5bar),可完美雾化;

1. The gun body is made of corrosion-resistant copper and nickel plating, and the nozzle and gun needle are made of 316 stainless steel, which has long service life and little wear;
2. The nozzle and air cap are made of Teflon material, which is more corrosion-resistant and has a longer service life;
3. The special air structure inside the gun body has the reaction speed of quickly opening and closing the gun (0.1 second on/off);
4. Caliber: 0.2, 0.3, 0.5, 0.8, 1.0, 1.2, 1.5 and 2.0mm;
5. External control features: adjustable flow and atomization;
6. Low pressure and high atomization spray gun (0.5bar), which can atomize perfectly;

应用于 be applied to

可喷: 胶水、油漆、清漆、油脂、标识油墨、香料、药水、防腐剂、陶瓷釉、着色剂.....
行业: 制鞋行业、皮革行业、点胶行业、钢材行业、电子行业、精细喷涂.....

Sprayable: glue, paint, varnish, grease, marking ink, perfume, liquid medicine, preservative, ceramic glaze, colorant ...
Industry: shoemaking industry, leather industry, dispensing industry, steel industry, electronics industry, fine spraying...

技术参数 technical parameter

产品名称 product name	喷雾阀 spray valve	刮胶阀 Rubber scraper valve
材料压力 Material pressure	max.4bar	max.10bar (max.1000kpa/max.145psi)
控制空气压力 Control air pressure	min.5bar	56bar (500-600kap/72.5-87psi)
雾化空气压力 Atomized air pressure	max.0.5-5bar	无
规格 specifications	115*30*15mm	139*W*87mm
重量 weight	275g	530g

EFD接触式点胶阀/喷雾阀系列
EFD contact dispensing valve/spray valve series



型号：NS . DJF.02j

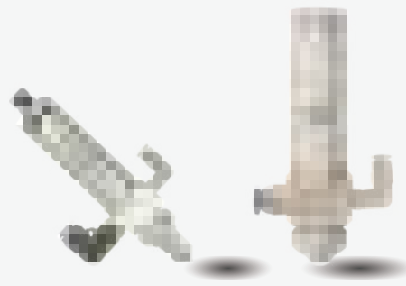

型号：NS . PWF.02



✓ 产品介绍 Product introduction

胶阀的设计最适合低粘度流体精密点胶, 且重复点胶的一致性极高。由于不锈钢针头的关闭位置在胶阀的针头转接头内, 避免了在点胶间隔中胶阀内出现残胶。
喷雾阀可以雾化极微量的流体, 并喷涂在直径为4.3 - 50.8 mm (0.17 - 2.0")的圆形或长直径为165.1 mm (6.5")的扇形范围内。

The design of glue valve is most suitable for precise dispensing of low viscosity fluids, and the consistency of repeated dispensing is extremely high. Because the closed position of the stainless steel needle is in the needle adapter of the glue valve, the occurrence of residual glue in the glue valve during the glue dispensing interval is avoided. The spray valve can atomize a very small amount of fluid and spray it in a circle with a diameter of 4.3-50.8 mm (0.17-2.0 ") or a sector with a long diameter of 165.1 mm (6.5").

✓ 产品特点 Product features

- 1•低维护设计 1. Low maintenance design
- 2•胶阀内无残胶 2. No residual glue in the glue valve
- 3•断胶干净 3. Clean broken glue.

✓ 应用于 be applied to

- 催化剂 • 记号墨 • 硅油 • 溶剂 • UV胶.....
Catalyst, marking ink, silicone oil, solvent and UV glue

规格与参数 Specifications and parameters

产品名称 product name	接触式点胶阀 Contact dispensing valve	喷雾阀 spray valve
尺寸 measure	114.6*26.9mm	104.6*26.9mm
重量 weight	317.5克	405.3克
胶阀启动压力 Starting pressure of valve	4.8-6.2 bar (70-90 psi)	4.8-6.2 bar (70-90 psi)
最大流体压力 Maximum fluid pressure	20.7 bar (300 psi)	20.7 bar (300 psi)
最高操作温度 Maximum temperature	43°C(110° F)	102°C(215° F)
工作频率 Working frequency	超过400次/分钟 Over 400 times/minute	超过400次/分钟 Over 400 times/minute
卡圈 closing ring	尼龙 nylon	尼龙 nylon
核心部件 Core component	303 不锈钢 303 stainless steel	303 不锈钢 303 stainless steel

自动喷枪系列 Automatic spray gun series



型号：WA-101系列

产品介绍 Product introduction

自动喷漆枪与自动喷涂机、往复喷涂机和喷涂机器人等组合使用，适合批量生产用喷枪。

Automatic paint spraying gun is combined with automatic spraying machine, reciprocating spraying machine and spraying robot, which is suitable for batch production.

产品特点 Product features

1. 具有相对较高的材料压力，将要喷涂的材料通过高压输送到喷枪，通过喷枪的MIX芯使材料形成扇形雾化；
2. 通过辅助空气进行二次辅助精细雾化，可根据材料的粘度调节辅助气压的小(0.24mpa-0.29Mpa可调)精细雾化；
3. 涂料浪费少，反弹小上漆率为85%-93%；
4. 可以喷涂高粘度材料；5. MIX混合芯有不同的口径，可根据材料粘度选择口径；

1. has a relatively high material pressure, the material to be sprayed is conveyed to the spray gun through high pressure, and the material is atomized in through the MIX core of spray gun;
2. Secondary auxiliary fine atomization is carried out by auxiliary air, and the small auxiliary air pressure (adjustable from 0.24 MPa to 0.29 MPa) can be adjusted according to the viscosity of the material;
3. Less paint waste, less rebound and 85%-93% painting rate;
- 4 high viscosity materials can be sprayed;
5. MIX mixed cores have different calibers, and the caliber can be selected according to the viscosity of the material;

应用于 be applied to

• 催化剂 • 涂布材料 • 油脂 • 油墨 • 液体助焊剂 • 油 • 硅胶 • 溶剂

Catalyst coating material grease ink liquid flux oil silica gel solvent

规格与参数 Specifications and parameters

产品名称 product name	自动喷枪 Automatic spray gun
所用空压机 Used air compressor	0.8、1.0、1.3、1.5、1.8mm
喷嘴口径 Nozzle diameter	317.5克
喷涂方式 Spraying method	压送式 Press-feed type
喷幅大小 Spray amplitude size	190-240mm
喷涂空气压力 Spraying air pressure	0.24mpa-0.29Mpa
喷涂距离 Spraying distance	200mm
喷出量 Ejection quantity	150-310mL/min

胶枪系列 Glue gun series



复动式顶针式胶阀
Double-acting thimble rubber valve
尺寸: (D) 21X (H) 160



复动式顶针式AB胶阀
Double-acting thimble AB rubber valve
尺寸: (D) 55X (H) 175

技术参数technical parameter

产品名称 product name	复动顶针式胶阀 Double-acting rubber valve
产品型号 product model	复动/双动顶针式 Double-acting/double-acting thimble
操作黏度 Operating viscosity	1-1.000.000cps
入料压力 Feeding pressure	<30KG
入料口尺寸 Inlet size	1/8"npt (f)
最小吐出量 Minimum spit volume	0,01ml
气缸 cylinder	复动双气缸 Double acting cylinder
使用气源 Use gas source	4-7kgf/cm
操作速率 Operating rate	<300-600/min

技术参数technical parameter

产品名称 product name	复动回吸式AB胶阀 Double-acting suction AB glue valve
产品型号 product model	回吸式 Suction type
操作黏度 Operating viscosity	1-1.000.000cps
入料压力 Feeding pressure	<30KG
入料口尺寸 Inlet size	1/8"npt (f)
最小吐出量 Minimum spit volume	0.01ml
气缸 cylinder	复动双气缸 Double acting cylinder
使用气源 Use gas source	4-7kgf/cm
操作速率 Operating rate	<600/min



尺寸: (D) 55X (H) 175

技术参数technical parameter

产品名称 product name	21B顶针式点胶阀 21B thimble dispensing valve
产品型号 product model	复动顶针式 Double action thimble type
操作黏度 Operating viscosity	1-1.000.000cps
入料压力 Feeding pressure	<30KG
入料口尺寸 Inlet size	1/8"npt (f)
最小吐出量 Minimum spit volume	0.01ml
气缸 cylinder	复动双气缸 Double acting cylinder
使用气源 Use gas source	4-7kgf/cm
操作速率 Operating rate	<600/min



21B顶针式胶阀
21B thimble dispensing valve
尺寸D*H: 21*165mm方形
重量/weight: 200G

技术参数technical parameter

产品名称 product name	回吸式点胶阀 Back-suction dispensing valve
产品型号 product model	NS.PF.30HX
液体粘度 Liquid viscosity	50-10000pa.s
工作气压 working air pressure	0.4-0.6Mpa
工作胶压 Working rubber pressure	0.2-1Mpa
适用液体材料 suitable liquid materials	低-中粘度 Low, medium and high viscosity
使用温度范围 Operating temperature range	5-60°C
料口径 Feed diameter	G 1/4-19
出料口径 Discharge caliber	3mm



回吸式点胶阀
Back-suction dispensing valve
驱动方式 往复式活塞式
Driving mode reciprocating piston type
阀体重量: 383g

技术参数technical parameter

产品名称 product name	双气缸双液点胶阀 Double-cylinder dispensing valve
产品型号 product model	回吸式 Suction type
操作黏度 Operating viscosity	1-1.000.000cps
入料压力 Feeding pressure	<30KG
入料口尺寸 Inlet size	1/8"npt (f)
最小吐出量 Minimum spit volume	0.01ml
气缸 cylinder	复动双气缸 Double acting cylinder
使用气源 Use gas source	4-7kgf/cm
操作速率 Operating rate	<600/min

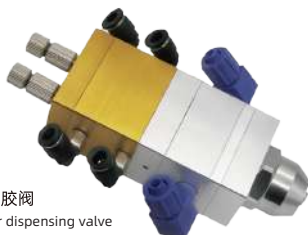

双气缸双液点胶阀
Double-cylinder dispensing valve
尺寸D*H: 32*42*115mm方形
重量: 618g

高精度螺杆阀系列

High precision screw valve series

专注精密流体控制经验十几年+

More than ten years experience in precision fluid control+

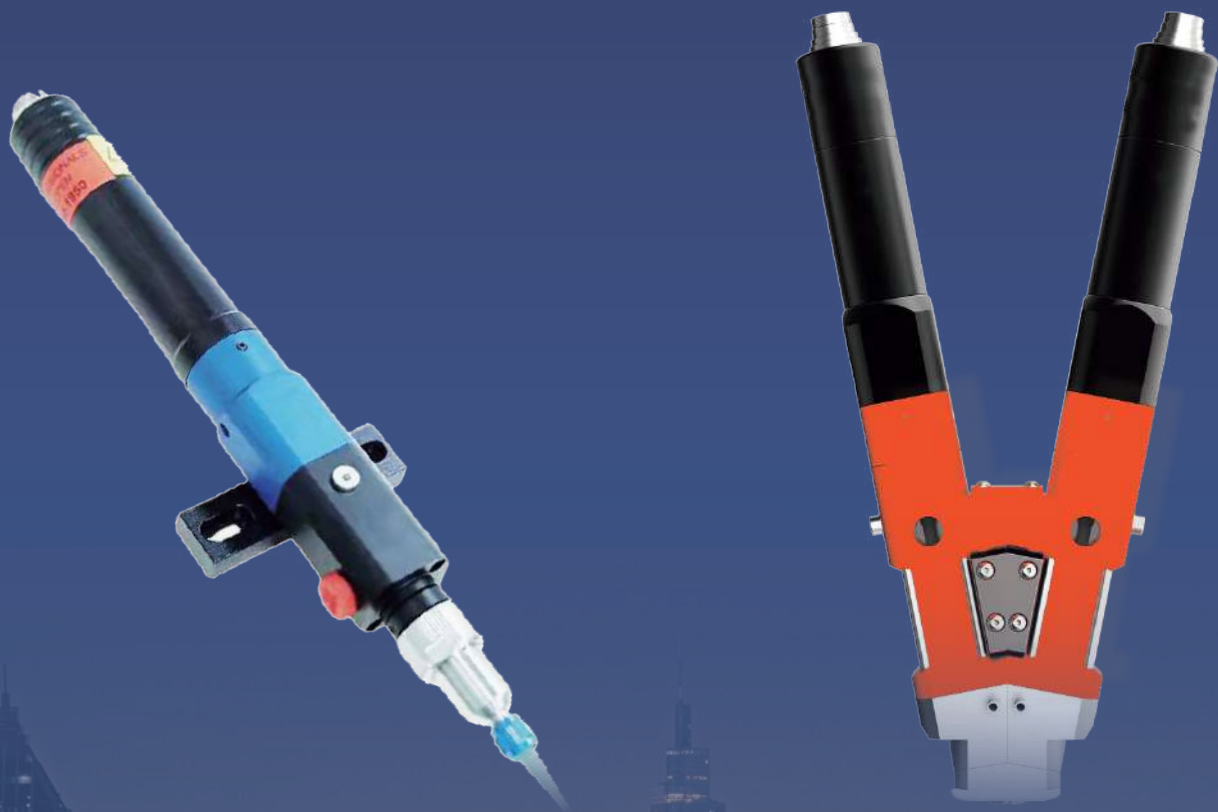

单液螺杆阀

Single liquid screw valve

型号: NS.LGF.01



螺杆阀适用于小流量介质输送,采用偏心螺旋结构设计,通过转子在定子型腔内绕轴线做行星回转运动,将螺杆与定子间形成的密闭腔内胶水沿转子螺旋线连续地、均匀地而且容积恒定地排出。输送过程不对介质产生剪切作用,因此不会对介质性状产生任何影响。同时可以通过电机反转,轻松实现介质回吸功能,确保介质和材料的清洁度,完全解决介质的滴漏、拉丝问题。

高应用度螺杆阀为高精度容积式定量输送泵,通过简单控制电机转速即可获得所需的精密流量输出,广泛应用于各种高精度定量输送场合。适用于多种类别的介质输送:胶水、脂、油、油漆、密封胶、粘合剂、硅树脂和高磨蚀性介质等各种粘度的流体。

The screw valve is suitable for conveying small flow media and adopts an eccentric spiral structure design. By rotating the rotor around the axis in the stator cavity, the closed cavity glue formed between the screw and the stator is continuously distributed along the rotor thread line. Evenly and consistently discharge. The conveying process does not produce shear effects on the medium, therefore it will not have any impact on the properties of the medium. At the same time, the medium suction function can be easily achieved by reversing the motor, ensuring the medium and the cleanliness of the material completely solves the problems of medium leakage and wire drawing.

The high application screw valve is a high-precision volumetric quantitative conveying pump, which can achieve the required precision flow output by simply controlling the motor speed. It is widely used in various high-precision quantitative conveying situations. Suitable for various types of media conveying: fluids with various viscosities such as glue, grease, oil, paint, adhesive, silicone resins, and highly abrasive media.



产品特点 Product features

1. 针头前端无残胶拉丝现象

螺旋结构设计,自由调节正反转实现回吸功能,完全解决介质的拉丝和残胶现象;

2. 无脉动,对物料无剪切

恒定容积式螺杆泵在输送过程中不会产生脉动,不会对介质产生剪切作用,因此不会对介质性状产生任何影响;

3. 不受液位高低影响,不受粘度变化影响

介质液位变化,粘度变化等不会影响到螺杆阀的输送精度,从而避免频繁调节点胶参数;

4. 含颗粒物介质也能定量输送

螺杆阀输送高含固量介质时不会对颗粒物造成损伤;

5. 易清洗易更换

螺杆阀结构较简单,能很方便的清洗及更换配件,不影响生产;

6. 较为简单的供料方式

可以应用不同供料方式,只需要能保证一定的压力使介质进入螺杆阀入口即可,不需要频繁调节供料参数。

1. There is no residual adhesive drawing phenomenon at the front end of the needle

Spiral structure design, freely adjustable forward and reverse to achieve suction function, completely solving the problem of wire drawing and residual glue in the medium;

2. No pulsation, no shearing of materials

The constant volume screw pump does not produce pulsation during transportation and does not have any shear effect on the medium, so it will not have any impact on the characteristics of the medium;

3. Not affected by liquid level and viscosity changes

Changes in medium liquid level and viscosity will not affect the conveying accuracy of the screw valve, thus avoiding frequent adjustment of dispensing parameters;

4. Medium containing particulate matter can also be quantitatively transported

The will not cause damage to particles when conveying high solid content media;

5. Easy to clean and replace

The screw valve has a simple structure and can be easily cleaned and replaced with accessories without affecting production;

6. A relatively simple feeding method

Different feeding methods can be applied, as long as a certain pressure can be ensured to allow the medium to enter the inlet of the screw valve, without the need for frequent adjustment of feeding parameters.



应用行业 be applied to

·光学粘合(粘合剂点胶,以获得更好的图像资料)·保形涂层(一种防护漆的综合应用)·筑坝&填充(高度复杂区域的保护)·顶部密封(精确点胶,提供可靠保护)
·底部填充(导电粘合剂点胶)·微量点胶(液体物料的高精度点胶)·封装(电子工业封装化合物的点胶)

Optical bonding (adhesive dispensing to obtain better image data), conformal coating (comprehensive application of a protective paint), damming & filling (protection of highly complex areas), top sealing (precise dispensing to provide reliable protection), bottom filling (conductive adhesive dispensing), micro dispensing (high precision dispensing of liquid materials) and packaging (dispensing of packaging compounds in electronic industry)

(1)最大输送压力和自密封性,随粘度的降低而降低,随粘度的增加而增加。详情请咨询制造商。

(2)点胶精度与点胶泵旋转一圈所输送的物料的绝对偏差有关。具体取决于所输送物料的粘稠度。

(1) The maximum conveying pressure and self-sealing property decrease with the decrease of viscosity and increase with the increase of viscosity. Please consult the for details.

(2) The accuracy of dispensing is related to the absolute deviation of the materials delivered by the dispensing pump once rotating. Depending on the viscosity transported material.



单组份螺杆阀选型参数 Selection parameters of single-component screw valve

型号 model	每转流量 Flow per revolution	出胶速度 Glue outlet speed	入料口 Feed inlet	出料口 discharge hole	阀净重 Valve net weight
NS.LGF.003	0.003mL	0.03mL/min ~ 0.36mL/min	1/8"	LUER LOCK	350g
NS.LGF.010	0.01 mL	0.1 mL/min ~ 1.2mL/min	1/8"	LUER LOCK	350g
NS.LGF.060	0.06mL	0.6mL/min ~ 7.2mL/min	1/8"	LUER LOCK	400g
NS.LGF.200	0.2mL	2mL/min ~ 24.0mL/min	1/8"	LUER LOCK	500g



产品参数 Product parameter

产品型号 product model	单液螺杆阀 Flow per revolution	产品型号 product model	单液螺杆阀控制器 Single-liquid screw valve controller
精度 precision	±2%	显示屏 monitor	4.3"触摸屏 4.3"touch screen
重复精度 repeatability	±1%	控制数量 Control quantity	1 (可定制: 例如: 一控四、一控八等不同控制器 1 (Customizable: for example, different controllers such as one control four and one control eight.
出胶速度 Flow per revolution	0.6mL/min ≤ μ ≤ 7.2mL/min (看选择型号)	控制信号 pilot signal	开关量信号 Switch signal
每圈输送量 Conveyance per lap	0.06mL/转	电源 Power Supply 	AC110-250V y 50/60HZ
介质粘度 Medium viscosity	≤1000000cps	环境温度 ambient temperature	10-40 °C
介质压力 Medium pressure	≤ 0.6MPa	控制螺杆阀端口 Control screw valve portV	8芯航空插 Flow per revolution
介质温度 medium temperature	≤80°C	设备联机端口 Device online port	两芯航空插 (接收开关量信号) Two-core aviation plug (receiving switch signal)
使用电压 Operating voltage	相AC 220V±5%、50±2Hz	撞针/喷嘴材质 Firing pin/nozzle material	超硬质合金 Superhard gold
外型尺寸 outline dimension	253(L)mm×33(φ)mm	外型尺寸 outline dimension	250(W) *220(D)*125(H)约3.4 kg~3.6kg

精密单页螺杆阀外型尺寸 Dimensions of precision single-page screw valve

NS.LGF.003与010外形尺寸图

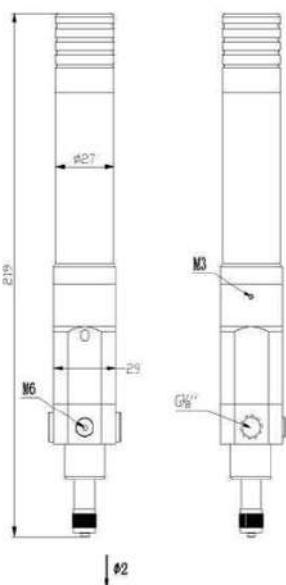

NS.LGF.060外形尺寸图

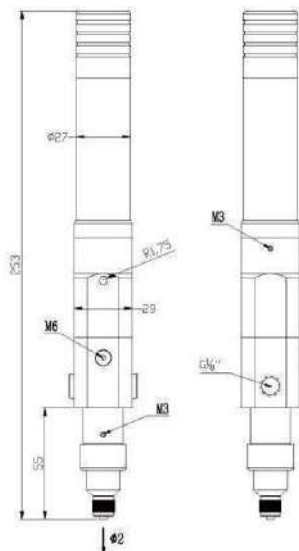

NS.LGF.200外形尺寸图

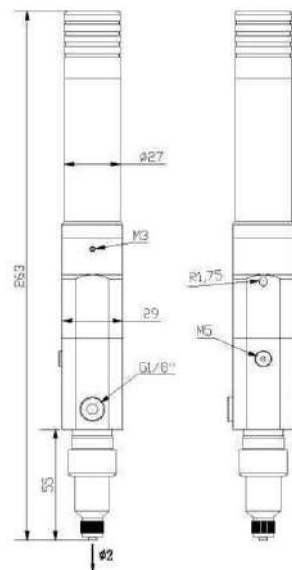

双组份螺杆阀

Two-component screw valve

型号: NS.LGF.02



可选止胶阀
Optional glue check valve

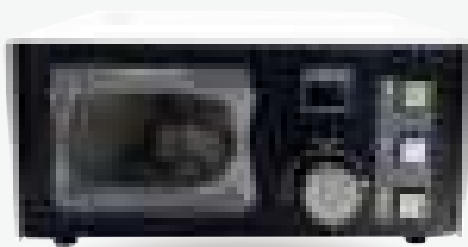

双组份混合和点胶系统:真正实现了双组份物料的容积式输出。双组份液体和糊状物的最小投配量是精确混合和投配的。通过对单组份物料的目标控制,将混合比设置为小数点后两位。无论物料的粘度如何,都能实现清洁、可靠的物料输送。

Two-component mixing and dispensing system: the volumetric output of two-component materials is truly realized. The minimum dosage of two-component liquid and paste is accurately mixed and dosed. Through the target control of one-component materials, the mixing ratio is set to two decimal places. No matter what the viscosity of the material is, it can realize clean and reliable material transportation.

产品特点 Product features

- 针尖部分无残留,无溢胶,点胶效果更优越;
- 与粘度无关的点胶;
- 点胶剂量与输入压力无关;
- 混合比例可调,适合各种混合比例AB胶水;
- 点胶压力0~40bar;

There is no residue on the needle tip and no glue overflow, and the glue dispensing effect is superior;
Dispensing that has nothing to do with viscosity;
Dispensing dose has nothing to do with input pressure;
Adjustable mixing ratio, suitable for AB glue with various mixing ratios;
Dispensing pressure is 0~40bar;

产品参数 Product parameter

产品型号 product model	双组份螺杆阀 Two-component screw valve	产品型号 product model	双组份螺杆阀控制器 Two-component screw valve controller
精度 precision	±2%	显示屏 monitor	4.3"触摸屏 4.3" touch screen
重复精度 repeatability	±1%	控制数量 Control quantity	1 (可定制:例如:一控四、一控八等不同控制器) 1 (Customizable: for example, different controllers such as one control four and one control eight.)
出胶速度 Flow per revolution	0.6mL/min ≤ μ ≤ 7.2mL/min (看选择型号)	控制信号 pilot signal	开关量信号 Switch signal
每圈输送量 Conveyance per lap	0.06mL/转	电源 Power Supply nbsp;	AC110-250V y 50/60HZ
介质粘度 Medium viscosity	≤1000000cps	环境温度 ambient temperature	10-40 °C
介质压力 Medium pressure	≤ 0.6MPa	控制螺杆阀端口 Control screw valve portV	8芯航空插 Flow per revolution
介质温度 medium temperature	≤80°C	设备联机端口 Device online port	两芯航空插 (接收开关量信号) Two-core aviation plug (receiving switch signal)
使用电压 Operating voltage	相AC 220V±5%、50±2Hz	撞针/喷嘴材质 Firing pin/nozzle material	超硬质合金 Superhard gold
外型尺寸 outline dimension	253(L)mm×33(φ)mm	外型尺寸 outline dimension	250(W) *220(D)*125(H)约3.4 kg~3.6kg

双组份自动供胶系统

Two-component automatic glue supply system



双组分自动供胶系：配备补偿供胶功能，在比例失调时进行报警，以防阀体的损坏。在供胶的过程中检测供胶比例，使供胶结束时两组份胶水同时用完，减少胶水的浪费。常规供胶系统：无法监测出胶比例与胶水残留。

Two-component automatic glue supply system: equipped with compensation glue supply function to give an alarm when the proportion is out of balance to prevent the valve body from being damaged. In the process of glue supply, the proportion of glue supply is detected, so that the two components of glue are used up at the same time when the glue supply is over, and the waste of glue is reduced. Conventional glue supply system: unable to monitor the glue ratio and glue residue.

螺杆阀制冷温控器

Screw valve refrigeration thermostat

温控表
用于动态调整&检测
制冷块温度

温度表
用于检测冷
却液温度

散热
风扇



制冷截流阀(水冷)

Refrigeration shut-off valve (water cooling)



电子制冷控制系统 >>

优势：

大流量水循环降温，最低制冷温度可达-20℃传统的气制冷方式AB胶每15s需要排胶一次，电子制冷方式每45秒排胶一次。电子制冷方式只需要电源即可，节约气源。温控器可以根据设定温度动态调节温度。风扇规格12025，采用超静音设计。

Advantages: Large-flow water circulation can cool down, and the lowest refrigeration temperature can reach -20°C. The traditional gas refrigeration method needs to discharge the glue once every 15s, and the electronic refrigeration method needs to discharge the glue once every 45s. Electronic refrigeration only needs power supply, saving gas source. The thermostat can dynamically adjust the temperature according to the set temperature. The fan specification is 12025, which adopts ultra-quiet design.

参数 parameter	数值 numerical value
显示屏 monitor	4.3寸触摸屏 4.3 inch touch screen
模式时间 Mode time	自动 / 时间 Automatic/Time
进气口 admitting port	6mm气管快插 6mm tracheal insertion
出气口 air vent	6mm气管快插 6mm tracheal insertion
电源 Power Supply 	AC 220V

单组份螺杆阀

One-component screw valve

螺杆阀是一个真正的容积式点胶系统，其采用高精度点胶技术，能够实现最小量的单组份流体输送。基于久经考验的无限循环活塞原理，能够实现从水状到糊状液体的完美点胶。无论物料的粘稠度如何，都能实现清洁、过程可靠的精确剂量点胶。

从控制单元到点胶泵，都代表着高质量。它始终遵循着“更小巧、更精确、更经济”的座右铭，适用于手动工作站(如工作台应用)或半自动和全自动操作。

Screw valve is a real volumetric dispensing system, which adopts high-precision dispensing technology and can realize the minimum amount of one-component fluid transportation. Based on the tried and tested principle of infinite circulation piston, it can realize the perfect dispensing from water to paste liquid. No matter what the viscosity of the material is, it can realize clean and reliable accurate dose dispensing. From the control unit to the dispensing pump, it represents high quality. It always follows the motto of "smaller, more accurate and more economical" and is suitable for manual workstations (such as workbench applications) or semi-automatic and fully automatic operations.

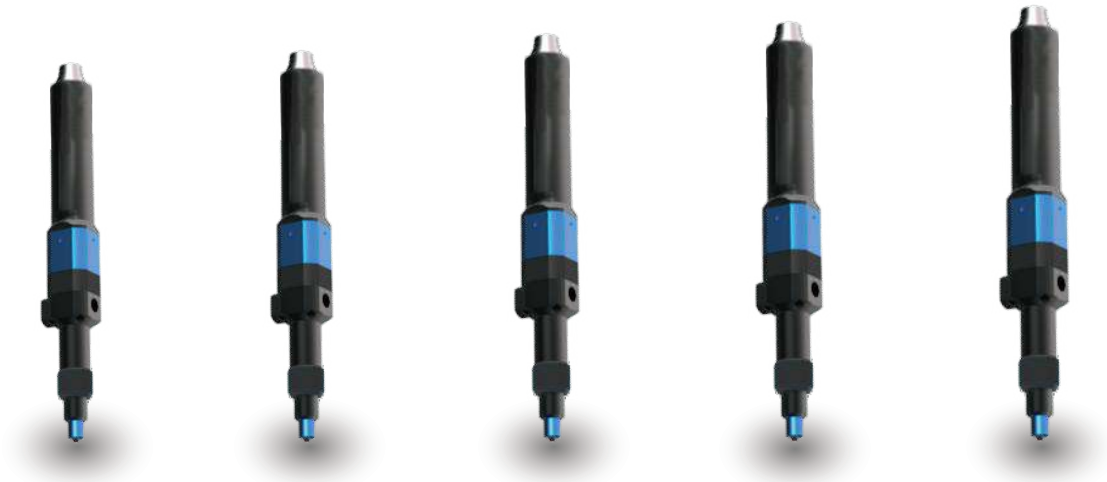

产品参数 Product parameter

产品系列型号 Product series model	NS.LGF300	NS.LGF330	NS.LGF450	NS.LGF600	NS.LGF700 ^{3D}
外形尺寸 outline dimension	长度216 mm *33 mm	长度225 mm *33 mm	长度228 mm *33 mm	长度274 mm *40mm	长度274 mm *40mm
重量 weight	280g	300g	300g	650g	650g
工作压力 working pressure	0-6bar	0-6bar	0-6bar	0-6bar	0-6bar
输送压力 Conveying pressure	20 bar	20 bar	20 bar	20 bar	10bar
粘稠度 viscosity	水状到糊状 Water to paste	水状到糊状 Water to paste	水状到糊状 Water to paste	水状到糊状 Water to paste	水状到糊状 Water to paste
容积流量 volume flow	0.12-1.48ml/min	0.2-3.3ml/min	0.5-6.0ml/min	1.4-16.0ml/min	5.3-60.0ml/min
最小投配量 Minimum dosing quantity	0.001 ml	0.002 ml	0.004 ml	0.015 ml	0.060 ml
输送精度 Conveying accuracy	±1%	±1%	±1%	±1%	±1%
工作温度 Working temperature	10-40°C	10-40°C	10-40°C	10-40°C	10-40°C
重复精度 repeatability	>99%	>99%	>99%	>99%	>99%

✓ 系统原理演示 Demonstration of system principle

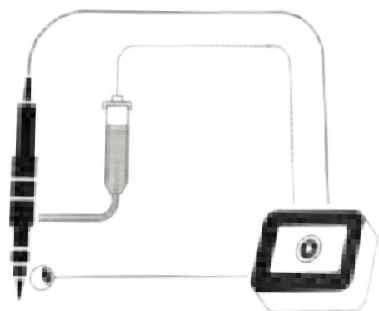

自流平液体，低粘度物料；
Self-leveling liquid, low viscosity material;

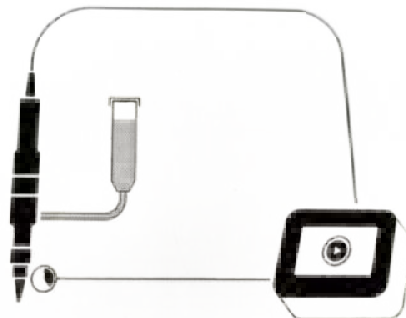

非自流平液体，中到高粘度物料包括压力进料；
Non-self-leveling liquid, medium to high viscosity materials including pressure feed;

✓ 应用案例 Application case

01

NA.LGF300最小投配量0.001毫升容积流量0.12-1.48毫升/分钟约计重量380克

The minimum dosage of NA.LGF300 is 0.001ml, the volume flow rate is 0.12-1.48ml/min, and the approximate weight is 380g.

02

NA.LGF450最小投配量0.004毫升容积流量0.5-6.0毫升/分钟约计重量410克

The minimum dosage of NA.LGF450 is 0.004 ml, and the volume is 0.5-6.0 ml/min, which is about 410g

03

NA.LGF600最小投配量0.015毫升容积流量1.4-16.0毫升/分钟约计重量750克

The minimum dosage of NA.LGF600 is 0.015ml, the volume flow rate is 1.4-16.0ml/min, and the approximate weight is 750g.

04

NA.LGF700最小投配量0.060毫升容积流量5.30-60.0毫升/分钟约计重量750克

The minimum dosage of NA.LGF700 is 0.060ml, the volume flow rate is 5.30-60.0ml/min, and the approximate weight is 750g.



在电子领域，越来越多的器件和外壳是粘合在一起的，而不是用螺丝固定的。螺杆阀系列点胶泵满足了市场对小型化的需求。这种微量点胶泵可以实现0.001ml的最小点胶量，因此几乎可用于任何点胶应用中。客户可以受益于高度精确、>99%的重复精度、过程稳定和清洁的点胶应用。

In the field of electronics, more and more devices and housings are bonded together instead of being fixed by screws. Screw valve series dispensing pump meets the market demand for miniaturization. This micro-dispensing pump can achieve the minimum dispensing amount of 0.001ml, so it can be used in almost any dispensing application. Customers can benefit from highly accurate, >99% repeatability, stable process and clean dispensing application.



双组份AB螺杆阀

Two-component AB screw valve

双组份混合和点胶系统:真正实现了双组分物料的容积式输出。双组份液体和糊状物的最小投配量是精确混合和投配的。通过对单组份物料的目标控制,将混合比设置为小数点后两位。无论物料的粘度如何,都能通过双组份实现清洁、可靠的物料输送。

双组份系列点胶泵由于具备回吸功能,能实现可控制的螺纹剪断;其压力监测可以实现过程的可靠性,此外还具备一些其他功能。双组份点胶泵操作简单、安全应用范围广。欢迎您亲自体验这种精密机械和先进的数字控制技术。

Two-component mixing and dispensing system: the volumetric output of two-component materials is truly realized. The minimum dosage of two-component liquid and paste is accurately mixed and dosed. Through the target control of one-component materials, the mixing ratio is set to two decimal places. No matter what the viscosity of the material is, it can realize clean and reliable material transportation through two components. Two-component series dispensing pump can realize controllable thread cutting because of its suction function; its pressure monitoring can realize the reliability of the process, and also has some other functions. The two-component dispensing pump is simple to operate and has a wide range of safe applications. You are welcome to experience this precision machinery and advanced digital control technology yourself.



产品参数 Product parameter

产品系列型号 Product series model	NS.LGF330.S(S代表: 双)	NS.LGF450.S	NS.LGF600.S
外形尺寸 outline dimension	228 mm x 163 mm	228 mm x 163 mm	301 mm x 163 mm
重量 weight	1230g	1230g	1880g
工作压力 working pressure	0-20 bar	0-20 bar	0-20 bar
输送压力 Conveying pressure	40 bar	40 bar	40 bar
粘稠度 viscosity	水状到糊状 Water to paste	水状到糊状 Water to paste	水状到糊状 Water to paste
容积流量 volume flow	0.1-6.6 ml/min(at 1:1)	0.2-12 ml/min(at 1:1)	0.6-32.0ml/min (at1:1)
最小投配量 Minimum dosing quantity	0.005 ml	0.010 ml	0.030 ml
输送精度 Conveying accuracy	±1%	±1%	±1%
工作温度 Working temperature	10-40°C	10-40°C	10-40°C
重复精度 repeatability	>99%	>99%	>99%

系统原理演示 Demonstration of system principle

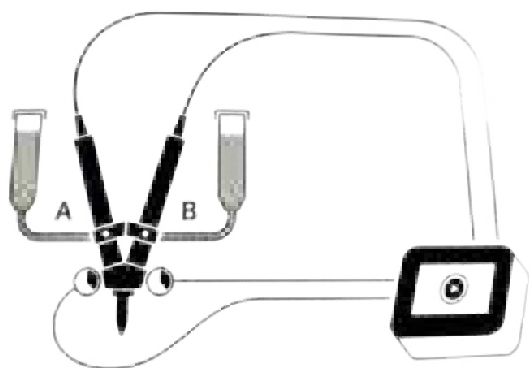

自调平液体,低粘度物料,包括传感器技术

Self-leveling liquid, low viscosity material, including sensor technology

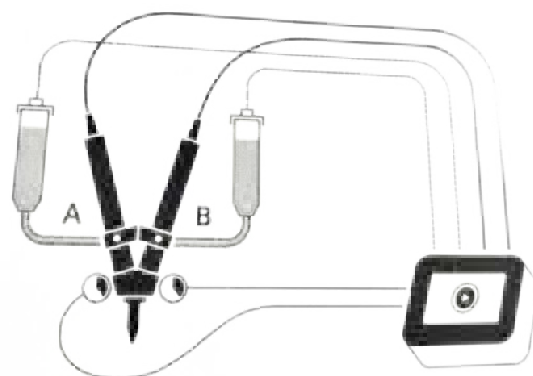

非自流平液体,中到高粘度物料,包括传感器技术和压力进料

Non-self-leveling liquid, medium to high viscosity materials, including sensor technology and pressure inlet.

应用案例 Application case

凭借着精确输送、重复的准确性、精确的投配量、与粘度无关和正确的混合比例等特性,双组份螺杆阀能很好地满足客户的预期。此双组份微量点胶泵非常适合医疗技术应用。通过使用双组份螺杆阀,客户可以从诸多优势中受益例如提高生产力、降低材料消耗和减少浪费。越来越小、越来越薄、越来越强大-在电子工业中,创新和节省空间的连接技术既不妨碍小型化,也不妨碍大规模生产。微量点胶泵,特别是双组份点胶泵NS.LGF330.S,有着良好的性能表现,其能实现0.001ml的最小投配量。在每种粘合剂应用中,无论它有多精细,例如将微型摄像头粘合到智能手机上时,该微量点胶泵都能凭借着清洁的粘合能力而成为此类应用的最佳选择。

With its precise conveying, repeated accuracy, precise dosage, viscosity independence, and correct mixing ratio, the two-component screw valve can meet customers' expectations well. This two-component micro dispensing pump is very suitable for medical technology applications. By using two-component screw valves, customers can benefit from many advantages such as increased productivity, reduced material consumption, and reduced waste. Getting smaller, thinner, and stronger - In the electronics industry, innovative and space saving connectivity technologies do not hinder miniaturization or large-scale production. Micro dispensing pump, especially the two-component dispensing pump NS LGF330.S, It has good performance and can achieve a minimum dosage of 0.001ml. In every adhesive application, no matter how fine it is, such as when bonding a miniature camera to a smartphone, this micro dispensing pump can become the best choice for such applications due to its clean adhesive ability.

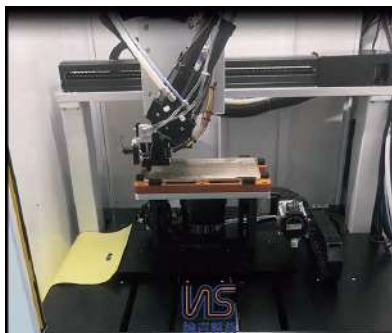

耗材配件规格选择表 Consumables Accessories Specification Selection Table

产品图片 Product picture	料号代码 Item code	产品名称 product name	规格型号 specifications and models	材质 texture of wood
	DD.03.00.0005-81	鲁尔接头密封圈 Ruhr joint sealing	6*1	氟胶 Fluoro-glue
	DD.04.08.0007-79	气缸 cylinder	56.1x33.9x33.2mm	标准气缸 Standard cylinder
	纳声定制 Nasheng custom made	压力传感器组件 Pressure sensor embly	PC10-4MS4w1C	纳声定制 Nasheng custom made
	DD.08.00.0009-1110	泛塞封 Pan plug seal	7.8*12.6*4.8 PEEK	PEEK PEEK
	NS.JGJ.JJ.0346	定子 stator	纳声螺杆阀点胶机定子[常规型(BASIC)] Stator of Nano-sonic Screw Valve Dispensing Machine [BASIC]	纳声定制 Nasheng custom made
	NS.JGJ.JJ.0347	转子 rotator	纳声螺杆阀点胶机转子[常规型/热熔型(BASIC)] Rotor of Nano-sonic Screw Valve Dispensing Machine [Conventional Type/Hot Melt Type (BASIC)]	纳声定制 Nasheng custom made
	纳声定制 Nasheng custom made	雷莫FGG 插头线 Remo FGG plug wire	00B-3芯/单头3米/高柔线 00B-3 cores/single head 3m/high flexible	纳声定制 Nasheng custom made
	NS.600.PJ.0009	旋转密封圈 Rotary sealing ring	18*7*4.5	氟胶 氟胶
	NS.600.PJ.0015	排胶块 Rubber discharge block	纳声定制 Nasheng custom made	纳声定制 Nasheng custom made
	NS.600.PJ.0016	堵头 choke plug	PC10-4MS纳声定制4w1C PC10-4MS nasheng customized 4w1C	纳声定制 Nasheng custom made
	NS.600.PJ.0012	料腔 Material cavity	纳声定制 Nasheng custom made	纳声定制 Nasheng custom made
	NS.600.PJ.0017	出胶嘴 Glue outlet nozzle	纳声定制 Nasheng custom made	纳声定制 Nasheng custom made
	NS.600.PJ.0008	O 形圈 O-ring	18*1.0	氟胶 Fluoro-glue
	纳声定制 Nasheng custom made	帕尔贴片 Parr patch	FPK2-19808NC	纳声定制 Nasheng custom made

精密点胶控制器系列

Precision dispensing controller series

产品性能

product performance

- 标配气压安定电路(PAT.)消除吐出量的偏差、实现优异的吐出精度。
- 紧凑型设计, 节省空间。

Standard air pressure stabilizing circuit (PAT.) eliminates the deviation of discharge quantity and realizes excellent discharge accuracy. Compact design saves space.



名称: 高精度数码点胶控制器
Name: high-precision digital dispensing controller

产品性能

product performance

- 提高压力变化的可追踪性。
- 实现更精细的涂布。
- 提升低粘度液剂的涂布稳定性, 易维护性。

Improve the traceability of pressure changes. Achieve finer coating. Improve the coating stability and maintainability of low viscosity liquid agent.



名称: 全功能数控型点胶控制器
Name: Full-function numerical control dispensing controller



名称: 单液智能点胶控制器(高端型)
Name: single liquid intelligent dispensing (high-end type)
型号: NS.DC.310HD

参数规格 Parameter specification

点胶方式 Dispensing method	空压方式 Air compression mode
控制方式 Control mode	微电子式/气压控制式 Microcomputer electronic/pneumatic control type
吐出模式 Spitting mode	定时模式/手动模式 Timed mode/manual mode
吐出压力/时间设定范围 Discharge pressure/time setting range	5~700 kPa/0.01~9,999 s
真空压力设定范围 Vacuum pressure setting range	0~20 kPa(供气400 kPa时)
输出信号 output signal	点胶完成输出/点胶中输出(切换式) Output dispensing/output dispensing (switching type)
电源及频率 Power supply and frequency	AC100-240V 50/60 Hz
供气压力 Air supply pressure	连接方式 attended mode Ø6一触式接头 6 One-touch connector 范围 range 吐出压力+100 kPa以上且最大至 800 kPa The discharge is above+ 100 kPa maximum is 800 kPa.
外形尺寸 outline dimension	W188xD198xH84 mm
重量 Heavy weight	3.4 KG

参数规格 Parameter specification

点胶方式 Dispensing method	空气脉冲方式 Air compression mode
控制方式 Control mode	微电脑控制电动/气动方式 Microcomputer electronic/pneumatic control type
点胶模式 Spitting mode	定时模式/手动模式 Timed mode/manual mode
吐出压力/时间设定范围 Discharge pressure/time setting range	0.030~0.500 MPa/0.001~9999.999 s
真空压力设定范围 Vacuum pressure setting range	-0.020~0MPa
输出信号 output signal	准备、点胶完成、点胶中、点胶循环中、电磁阀报警、错误、余量警告、通电中 Preparation, dispensing completed, dispensing in progress, dispensing cycle, solenoid valve alarm, residual power on.
电源及频率 Power supply and frequency	AC100-240V 50/60Hz
主要功能 Air supply pressure	水头差自动修正、自动防止漏滴、自动余量警告、点胶计数器、秒表、日英显示切换、供给压力错误、排气错误、真空压力错误、电磁阀错误、电磁阀警告。 Automatic correction difference, drip prevention, automatic residual warning, dispensing counter, stopwatch, Japanese-English vacuum pressure error, solenoid valve error and solenoid valve warning.
外形尺寸 outline dimension	W300xD300xH100 mm
重量 Heavy weight	5.8 KG

点胶控制器 (有源) 系列

Dispensing Controller (Active) Series

- 具备手动/自动点胶模式, 自动间隔时间点胶功能。
- 真空回吸功能, 能有效解决代粘度液体点胶后滴流现象。
- 配备各种接口方式, 方便与自动化设备连接。
- 采用数字显示方式方便精密调整吐胶时间。
- 自动存储设定参数, 即使断电也无需重新设置。

With manual/automatic dispensing mode and automatic dispensing function at intervals. Vacuum suction function can effectively solve the dripping phenomenon of viscous liquid after dispensing. Equipped with various interface modes to facilitate the connection with automation equipment. Digital display mode is used to adjust the dispensing time conveniently and accurately. Automatically store the setting parameters, even if the power is off, there is no need to reset them.

通用型供胶单元/压盘泵

Universal glue supply unit/platen pump

专注核心供胶单元解决方案经验十几年+

More than ten years of experience in focusing on core glue supply unit solutions+

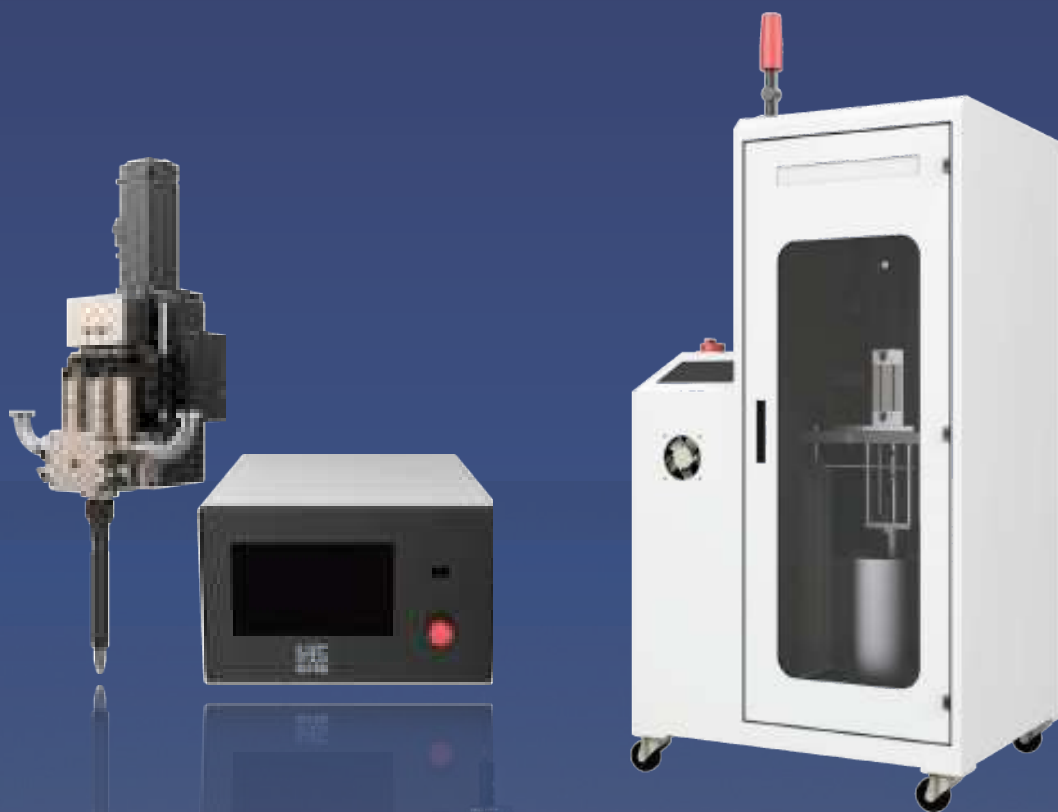

柱塞式注胶头 NS016

Plunger glue injection head NS016



控制器
controller

产品特点 Product features

- 单、双组分胶水混合比例固定
- 体积计量值不受温度，材料压力和粘度等影响
- 可重复精度和工艺可靠性高
- The mixing ratio of one-component and two-component glue is fixed.
- Volumetric values are not affected by temperature, material pressure and viscosity.
- High repeatability and process reliability.

通用特性 Universal characteristics

- 适用胶水：单组份或双组分胶水，从低粘度到高粘度，低、中、高填料胶水
 - 计量方式：体积计量（通过改变缸套的直径固定胶水比例）
- Applicable glue: one-component or two-component glue, from low viscosity to high viscosity, low, medium and high filler glue measurement
Method: volume measurement (fix the glue ratio by changing the diameter of cylinder liner)

规格参数 Specification parameter

最小点胶量 Minimum dispensing amount	0.1ml
最大点胶量 Maximum dispensing amount	(一次行程One trip)32ml
最大点胶粘度 Maximum dispensing viscosity	对于高粘度导热胶0.6 ml/s For high viscosity thermal grease
最大点胶速度 Maximum dispensing speed	对于常规硅胶 2 ml/s For conventional silica gel
最大加热温度 Maximum heating temperature	80 °C
整体重量 Overall weight	14 kg
电机功率 power of motor	400W 伺服电机actuating motor

产品特点 Product features

- 真空吸盘，包装换胶时胶水无气泡混入胶水
- 螺杆阀保证供料连续性
- 自动升降压力切换，在换料和正常生产过程
- 出料口压力侦测
- Vacuum sucker, when the packaging is changed, the glue has no bubbles mixed with the glue.
- Screw valve ensures continuous feeding.
- Automatic lifting pressure switching, during refueling and normal production.
- Discharge port pressure detection

通用特性 Universal characteristics

- 适用胶水料桶包装：5 加仑
- 适用胶水：单组份或双组分，高填料，高粘料胶水
- Suitable for glue barrel packaging: 5 gallons
- Applicable glue: one-component or two-component, high filler and high viscosity glue.

规格参数 Specification parameter

设备尺寸 Equipment size	936*1074*827 (mm)
重量 weight	130kg
供电 supply electricity	1~ 220 V, 50/60 Hz, CEE 6 A
螺杆泵容积 Screw pump volume	4ml/R
内径 inner diameter	285 mm
外径(base area)	305 mm
最大高度 Maximum height	420 mm

通用型供胶单元 NS260

Universal glue supply unit NS260



通用型供料单元 NS300

Universal feeding unit NS300



产品特点 Product features

- 料桶真空保证胶水免受空气、湿气等外部环境的干扰
- 料桶加热, 供料泵加热, 料管加热可选
- 通过独特的胶水循环功能, 保证胶水在静置状态下不会沉淀, 导致胶水材料的性能发生改变
- The vacuum of the bucket ensures that the glue is free from the interference of external environment such as air and moisture.
- Bucket heating, feed pump heating and feed tube heating are optional.
- Through the unique glue circulation function, it is ensured that the glue will not precipitate in the static state, which will lead to the change of the performance of the glue material.

通用特性 Universal characteristics

- 适用胶水类型: 硅胶/环氧/聚氨酯等
- 适用胶水: 单组份或双组份胶水, 从低粘度到高粘度, 适用低填料, 高填料胶水
- Applicable glue type: silica gel/epoxy/polyurethane, etc.
- Applicable glue: one-component or two-component glue, from low viscosity to high viscosity, suitable for low filler and high filler glue.

规格参数 Specification parameter

设备尺寸 Equipment size	1500*2038*700mm
料筒体积 Barrel volume	60L/45L/20L/10
供料泵缸套体积 Cylinder liner volume of feed pump	294 ml
供料泵能力/供气压力 Feed pump capacity/air supply pressure	3-10 bar/6 bar
搅拌速度 Feed pump capacity/air supply pressure	39 Rpm
最大加热温度 Maximum heating temperature	80 °C
电机功率 power of motor	400W 伺服电机actuating motor
整体重量 Overall weight	400 kg
最大加热温度 Maximum heating temperature	80 °C
管路长度 Pipeline length	3米/4米/5米/6米可选

空桶泵 (清桶泵、压盘泵)

Empty barrel pump (barrel cleaning pump, platen pump)



产品特点 Product features

- 直接和标准胶桶配合使用 (5加仑), 不需要往其他容器内转移材料, 可使原料浪费率降至极低。
- 适合粘度高、流动性差、含固量高的介质, 最高粘度达到1000000CPS。
- 体积精巧, 重量较轻, 操作简洁, 可以方便的安装和操作。
- 多种规格泵采用模块化组装方式, 适用于各种不同流量区间。
- 1. It can be directly used in conjunction with a standard plastic bucket (5 gallons) without transferring materials to other containers, which can reduce the waste rate of raw materials to a very low level.
- Suitable for media with high viscosity, poor fluidity and high solid content, with the highest viscosity reaching 1000000CPS.
- Compact size, light weight, simple operation and convenient installation and operation.
- Pumps of various specifications are assembled in a modular way, which is suitable for various flow intervals.

参数规格 Specification parameter

设备尺寸 Equipment size	910mm×700×970mm (气缸升高后高度为1370mm)		
重复精度 repeatability	±1%		
可输送介质 Transportable medium	①介质粘度Medium viscosity: ≤1000000cps		
	②介质压力Medium pressure: ≤0.6MPa		
	③介质温度medium temperature: ≤80°C		
流量参数Flow parameter			
型号 model	转速r otation speed	推荐出胶量 Recommended glue output	出胶压力 Glue outlet pressure
NS-1.5CC-36H	0~85rpm/min	0.18~2.5 ml/s	36 bar
NS-3CC-24H	0~85rpm/min	0.8~7 ml/s	24 bar
NS-6CC-24H	0~85rpm/min	2.5~21 ml/s	24 bar

高粘度胶水供胶单元 NS200

High viscosity glue supply unit NS200



产品特点 Product features

- 双向供料泵保证供料连续性
- 自动升降压力切换，在换料和正常生产过程
- 电阻式液位计，监控物料的使用情况
- 输出料压监控和自动调整功能

Two-way feeding pump ensures continuous feeding and automatic pressure switching. During refueling and normal production, the resistance level meter monitors the use of materials and outputs the functions of material pressure monitoring and automatic adjustment.

通用特性 Universal characteristics

- 适用胶水料桶包装：5 加仑
- 适用胶水：单组份或双组分，无填料，中高粘度胶水

Suitable glue bucket packaging: 5 gallons
of suitable glue: one-component or two-component, no filler, medium and high viscosity glue.

规格参数 Specification parameter

设备尺寸 Equipment size	900*1904*710 (mm)
重量 weight	230kg
供电 supply electricity	3~ 400 V, 50/60 Hz, CEE 16 A
泵一次行程体积 Pump stroke volume	294 cm ³
内径 inner diameter	285 mm
外径(base area)	305 mm
最大高度 Maximum height	420 mm

高粘度高填料胶水供胶单元 NS 800

High Viscosity and High Abasive Feeding unit ZZT 800



产品特点 Product features

- 双供料泵保证供料连续性
- 电阻式液位计，监控物料的使用情况
- 真空吸盘，确保换胶时胶水无气泡混入胶水
- 自动升降压力切换，在换料和正常生产过程

Double feed pumps ensure the continuity of feeding, and the vacuum sucker monitors the use of materials to ensure that the glue does not have bubbles mixed with the glue when changing the glue, and the pressure is automatically switched up and down.

通用特性 Universal characteristics

- 适用胶水料桶包装：5 加仑
- 适用胶水：单组份或双组分，高填料，高粘料胶水

Suitable glue bucket packaging: 5 gallons
of suitable glue: one-component or two-component, no filler, medium and high viscosity glue.

规格参数 Specification parameter

设备尺寸 Equipment size	900*1904*710 (mm)
重量 weight	230kg
供电 supply electricity	3~ 400 V, 50/60 Hz, CEE 16 A
泵一次行程体积 Pump stroke volume	294 cm ³
内径 inner diameter	285 mm
外径(base area)	305 mm
最大高度 Maximum height	420 mm

UV LED光源固化机

UV LED light source curing

专注UV固化整体解决方案经验十几年+

More than ten years experience in focusing on the overall solution of UV curing+

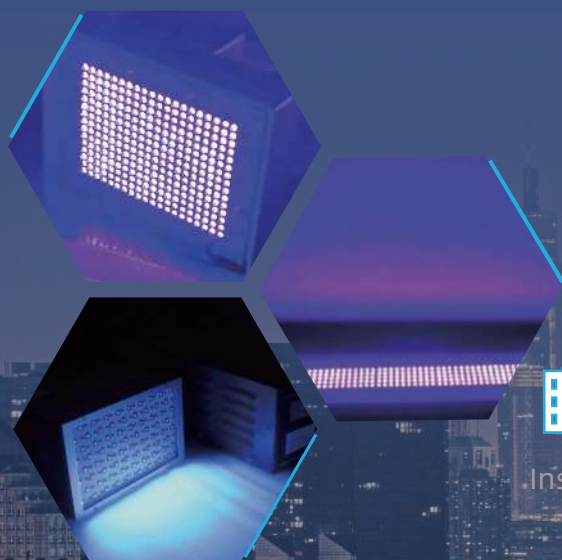
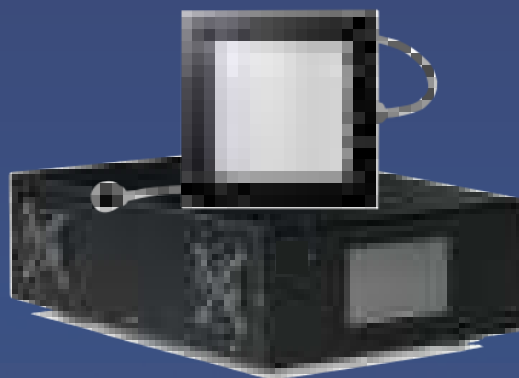

进口灯珠

Imported lamp beads

瞬间固化

Instantaneous curing

UV LED 点光源系列

UV LED point light source series

不同波长、不同规格尺寸，可按需定制

Different wavelengths, different specifications and sizes, can be customized as required.

产品特点 Product features

- ☑ 高功率输出 High power output
- ☑ 高温、LED异常报警功能 High temperature, LED abnormal alarm function
- ☑ 规格多样化满足多种需求 Diversified specifications to meet a variety of needs
- ☑ 精密光学设计、出光均匀 Precise optical design, uniform light output
- ☑ 散热优良、杜绝工件和照射物高温变形 Excellent heat dissipation, prevent high-temperature deformation of workpieces and irradiated objects.
- ☑ 任意规格可定制 Any specifications can be customized.

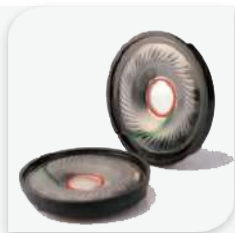

微型扬声器组装

Miniature loudspeaker assembly



手机摄像头定焦、组装

Focusing and assembly of mobile phone camera

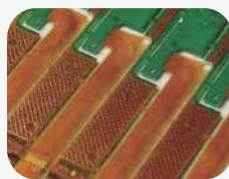

FPC 补强

FPC reinforcement



音圈马达组装

Voice coil motor assembly



TP 贴合

TP bonding

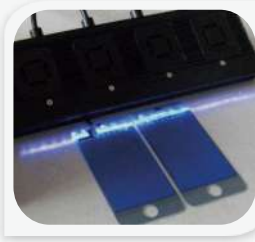

TP 贴合

TP bonding



指纹识别模块

Fingerprint identification module



半导体芯片

Semiconductor chip





产品典型场景 Typical product scene

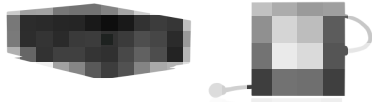
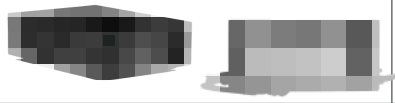
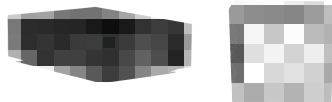

UV LED 选型系列

UV LED selection series

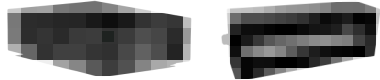
UV LED 面光源 UV LED surface light source

控制器+照射头 Controller+irradiation head	照射面积 Irradiated area	波长范围 wavelength coverage	消耗电功率 Consume electric power	散热方式 Heat dissipation mode
	100X100(mm)	365/395/405	240W/H	风冷/水冷 (可根据需求选择) Air cooling/water cooling (optional according to requirements)
	200X100(mm)	365/395/405	600W/H	风冷/水冷 (可根据需求选择) Air cooling/water cooling (optional according to requirements)
	200X200(mm)	365/395/405	600W/H	风冷/水冷 (可根据需求选择) Air cooling/water cooling (optional according to requirements)
	200X300(mm)	365/395/405	1800W/H	风冷/水冷 (可根据需求选择) Air cooling/water cooling (optional according to requirements)
	120X30(mm)	365/395/405	240W/H	风冷/水冷 (可根据需求选择) Air cooling/water cooling (optional according to requirements)
	240X30(mm)	365/395/405	480W/H	风冷/水冷 (可根据需求选择) Air cooling/water cooling (optional according to requirements)
	240X30X30(mm)	365/395/405	960W/H	风冷/水冷 (可根据需求选择) Air cooling/water cooling (optional according to requirements)

UV LED 线光源 UV LED line light source

一体式线光源 Integrated linear light source	照射面积 Irradiated area	波长范围 wavelength coverage	消耗电功率 Consume electric power	散热方式 Heat dissipation mode
	200X15(mm)	365/395/405	150W/H	风冷/水冷 (可根据需求选择) Air cooling/water cooling (optional according to requirements)
	300X15(mm)	365/395/405	240W/H	风冷/水冷 (可根据需求选择) Air cooling/water cooling (optional according to requirements)

UV点光源固化机

UV point light source curing machine



四通道点光源
Four-channel point source



八通道点光源
Eight-channel point light source



规格参数 Specifications

照射头 Irradiation head

365/385/395/405nm (可定制不同波段 Different bands can be customized)	透镜 (mm) lens	LE1.5	LE3.0	LE4.0	LE5.0	LE6.0	LE7.0	LE8.0	LE10	LE12	LE16	LE20
	最佳照射距离(mm) Optimum irradiation distance (mm)	7	9	14	16	17	21	27	25	27	38	40
	最大照度MW/CM ² Maximum illumination MW/cm ²	10000	8000	5200	4500	4200	2800	2200	1900	1300	800	600
电缆长度 Cable length	2M、5M可选 optional					冷却方式 Cooling mode		水冷/风冷 Water/air cooling				

照射头外型尺寸 Irradiation head size

A1 (透镜) /mm lens	Ø1.5	Ø2	Ø3	Ø4	Ø5	Ø6	Ø7	Ø8	Ø10	Ø12	Ø15	Ø16	Ø20
A2 (头部) /mm head	12.8	12.8	13.0	12.9	9.6	8.6	9.6	8.6	10.2	9.6	9.6	9.6	8.6

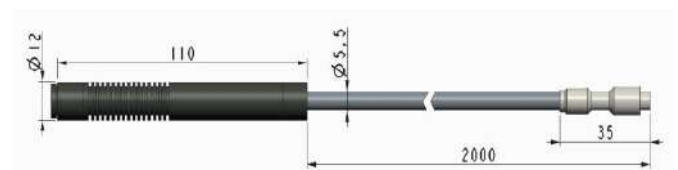
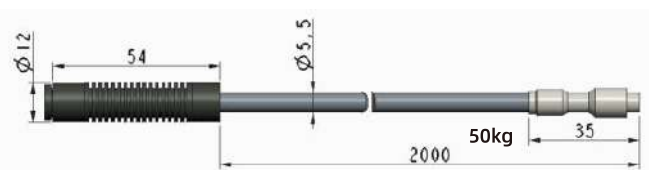
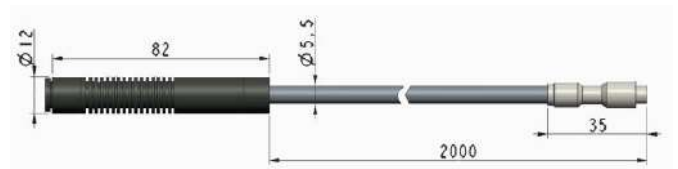
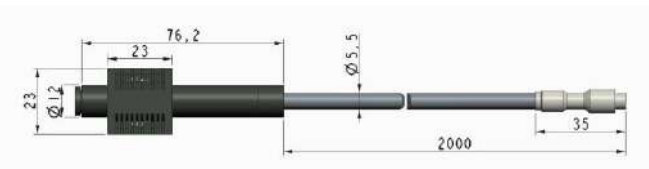
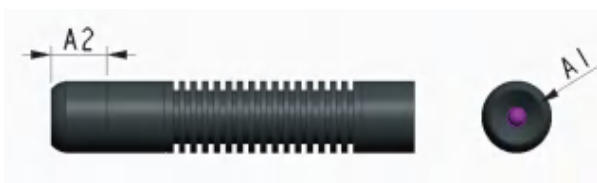

UV LED面光源固化机

UV LED surface light source curing machine



Model: NS.UV1010

应用行业 Application industry

UV涂料的干燥、印刷电路保护膜、IC卡、IC标签涂层、DVD媒介涂层UV胶带剥离、UV粘接、数码家电制造电子制造、PCB板涂层和芯片粘接、手机摄像头组装、DVD光头各种PVC、塑胶片、计算机键盘、手机按键、烘干固化微型扬声器、扬声器、受话器、耳机、耳塞等UV胶固化以及电声行业。

Drying of UV coating, protective film of printed circuit, IC card, IC label coating, stripping of UV tape of DVD medium coating, UV bonding, electronic manufacturing of digital household appliances, PCB coating and chip bonding, assembly of mobile phone camera, curing of various PVC, plastic sheets, computer keyboards, mobile phone buttons, drying and curing of micro-speakers, speakers, receivers, earphones and earplugs, and electro-acoustic industry.

技术参数 Technical Parameter

365/395/405mm照射头 Irradiation Head		控制器 controller	
发光(照射)面积 light-emitting area	100*100mm	电压 voltage	AC220V
照射距离 illumination distance	5-50	控制方式 Control mode	触控/脚踏/PLC Touch/pedal/PLC
光功率密度(W/CM ²) Optical power density (w/cm ²)	0-15	照射功率可调范围 Adjustable range of irradiation power	10%-100%可调 adjustable
散热方式 Heat dissipation mode	风冷/水冷(可根据需求选择) Air cooling/water cooling (demand selection)	照射模式(手动) Irradiation mode (manual)	通过按键/脚踏 By pressing a button/pedal
电缆长度 Cable length	2M、5M可选	照射模式(自动) Illumination mode (automatic)	设定照射时间0.1-999.9S Set irradiation time
光源推定寿命 Estimated life of light source	25000S	通讯控制 Communication control	I/O接口/实现与上位机远程控制 I/O Interface/Realization of Remote Control with Upper Computer
使用湿度/湿度范围 Use humidity/humidity range	-10	运行环境温度/湿度 Operating environment temperature/humidity	0°C-45°C (不结冰、不凝露) No freezing. No condensation.
输入电压 input voltage	220VAC 50Hz	保存环境温度/湿度 Preserve ambient temperature/humidity.	-10°C-60°C/ 30-85%RH (不凝露)
外形尺寸 outline dimension	140*97*100mm	外形尺寸 outline dimension	340*243*101.5mm



Model: NS.UV2020

应用行业 Application industry

UV涂料的干燥、印刷电路保护膜、IC卡、IC标签涂层、DVD媒介涂层UV胶带剥离、UV粘接、数码家电制造电子制造、PCB板涂层和芯片粘接、手机摄像头组装、DVD光头各种PVC、塑胶片、计算机键盘、手机按键、烘干固化微型扬声器、扬声器、受话器、耳机、耳塞等UV胶固化以及电声行业。

Drying of UV coating, protective film of printed circuit, IC card, IC label coating, stripping of UV tape of DVD medium coating, UV bonding, electronic manufacturing of digital household appliances, PCB coating and chip bonding, assembly of mobile phone camera, curing of various PVC, plastic sheets, computer keyboards, mobile phone buttons, drying and curing of micro-speakers, speakers, receivers, earphones and earplugs, and electro-acoustic industry.

技术参数 Technical Parameter

照射头 Irradiation Head		控制器 controller	
发光(照射)面积 Irradiated area	200*100mm	电压 voltage	AC220V
照射距离 illumination distance	5-50	控制方式 Control mode	触控/脚踏/PLC Touch/pedal/PLC
光功率密度(W/CM ²) Optical power density (w/cm ²)	0-15	照射功率可调范围 Adjustable range of irradiation power	10%-100%可调 adjustable
散热方式 Heat dissipation mode	风冷/水冷(可根据需求选择) Air cooling/water cooling (demand selection)	照射模式(手动) Irradiation mode (manual)	通过按键/脚踏 By pressing a button/pedal
电缆长度 Cable length	2M、5M可选 optional	照射模式(自动) Illumination mode (automatic)	设定照射时间0.1-999.9S Set irradiation time
光源推定寿命 Estimated life of light source	25000小时	通讯控制 Communication control	I/O接口/实现与上位机远程控制 I/O Interface/Realization of Remote Control with Upper Computer
使用湿度/湿度范围 Use humidity/humidity range	-10	运行环境温度/湿度 Operating environment temperature/humidity	0°C-45°C (不结冰、不凝露) No freezing. No condensation.
输入电压 input voltage	220VAC 50Hz	保存环境温度/湿度 Preserve ambient temperature/humidity.	-10°C-60°C/ 30-85%RH (不凝露)
外形尺寸 outline dimension	270*200*107.5mm	外形尺寸 outline dimension	340*243*101.5mm

UV LED面光源

UV LED surface light source



Model: NS.UV123

应用行业 Application industry

触摸屏侧边固化、FPC补强、排线连接器涂胶固化、条线涂胶工艺流水线作业、微型马达UV固定。

Curing the side of the touch screen, FPC reinforcement, gluing and curing the wire of the flat cable connector, line gluing process assembly line operation, and UV fixing of the micro motor.

技术参数 Technical Parameter

照射头 Irradiation Head		控制器 controller	
发光(照射)面积 Irradiated area	120*30mm	电压 voltage	AC220V
365/395/405mm 照射距离 illumination distance	5-50	控制方式 Control mode	触控/脚踏/PLC Touch/pedal/PLC
光功率密度(W/CM ²) Optical power density (w/cm ²)	0-15	照射功率可调范围 Adjustable range of irradiation power	10%-100%可调 adjustable
散热方式 Heat dissipation mode	风冷/水冷(可根据需求选择) Air cooling/water cooling (demand selection)	照射模式(手动) Irradiation mode (manual)	通过按键/脚踏 By pressing a button/pedal
电缆长度 Cable length	2M、5M可选 optional	照射模式(自动) Illumination mode (automatic)	设定照射时间0.1-999.9S Set irradiation time
光源推定寿命 Estimated life of light source	25000小时	通讯控制 Communication control	I/O接口/实现与上位机远程控制 I/O interface/Realization of Remote Control with Upper Computer
使用湿度/湿度范围 Use humidity/humidity range	-10	运行环境温度/湿度 Operating environment temperature/humidity	0°C-45°C (不结冰、不凝露) No freezing, No condensation.
输入电压 input voltage	220VAC 50Hz	保存环境温度/湿度 Preserve ambient temperature/humidity.	-10°C-60°C/ 30-85%RH (不凝露)
外形尺寸 outline dimension	162*120*70mm	外形尺寸 outline dimension	340*243*101.5mm

应用行业 Application industry

UV涂料的干燥、印刷电路保护膜、IC卡、IC标签涂层、DVD媒介涂层UV胶带剥离、UV粘接、数码家电制造电子制造、PCB板涂层和芯片粘接、手机摄像头组装、DVD光头各种PVC、塑胶片、计算机键盘、手机按键、烘干固化微型扬声器、扬声器、受话器、耳机、耳塞等UV胶固化以及电声行业。

Drying of UV coating, protective film of printed circuit, IC card, IC label coating, stripping of UV tape of DVD medium coating, UV bonding, electronic manufacturing of digital household appliances, PCB coating and chip bonding, assembly of mobile phone camera, curing of various PVC, plastic sheets, computer keyboards, mobile phone buttons, drying and curing of micro-speakers, speakers, receivers, earphones and earplugs, and electro-acoustic industry.

技术参数 Technical Parameter

照射头 Irradiation Head		控制器 controller	
发光(照射)面积 Irradiated area	240*30mm	电压 voltage	AC220V
365/395/405mm 照射距离 illumination distance	5-50	控制方式 Control mode	触控/脚踏/PLC Touch/pedal/PLC
光功率密度(W/CM ²) Optical power density (w/cm ²)	0-15	照射功率可调范围 Adjustable range of irradiation power	10%-100%可调 adjustable
散热方式 Heat dissipation mode	风冷/水冷(可根据需求选择) Air cooling/water cooling (demand selection)	照射模式(手动) Irradiation mode (manual)	通过按键/脚踏 By pressing a button/pedal
电缆长度 Cable length	2M、5M可选 optional	照射模式(自动) Illumination mode (automatic)	设定照射时间0.1-999.9S Set irradiation time
光源推定寿命 Estimated life of light source	25000小时	通讯控制 Communication control	I/O接口/实现与上位机远程控制 I/O interface/Realization of Remote Control with Upper Computer
使用湿度/湿度范围 Use humidity/humidity range	-10	运行环境温度/湿度 Operating environment temperature/humidity	0°C-45°C (不结冰、不凝露) No freezing, No condensation.
输入电压 input voltage	220VAC 50Hz	保存环境温度/湿度 Preserve ambient temperature/humidity.	-10°C-60°C/ 30-85%RH (不凝露)



Model: NS.UV243

UV LED面光源/固化炉

UV LED surface light source/curing furnace



Model: NS.UV2433

应用行业 Application industry

触摸屏侧面固化、FPC补强、排线连接器线涂胶固化、条线涂胶工艺流水线作业、微型马达UV固定。

Curing the side of the touch screen, FPC reinforcement, gluing and curing the wire of the flat cable connector, line gluing process assembly line operation, and UV fixing of the micro motor.

技术参数 technical parameter

照射头 Irradiation Head		控制器 controller	
发光(照射)面积 Irradiated area	240*30*30mm	电压 voltage	AC220V
照射距离 Illumination distance	5-50	控制方式 Control mode	触控/脚踏/PLC Touch/pedal/PLC
光功率密度(W/CM ²) Optical power density (w/cm ²)	0-15	照射功率可调范围 Adjustable range of irradiation power	10%-100%可调 adjustable
散热方式 Heat dissipation mode	风冷/水冷(可根据需求选择) Air cooling/water cooling (demand selection)	照射模式(手动) Irradiation mode (manual)	通过按键/脚踏 By pressing a button/pedal
电缆长度 Cable length	2M、5M可选	照射模式(自动) Illumination mode (automatic)	设定照射时间0.1-999.9S Set irradiation time
光源推定寿命 Estimated life of light source	25000小时	通讯控制 Communication control	I/O接口/实现与上位机远程控制 I/O Interface/Realization of Remote Control with Upper Computer
使用湿度/湿度范围 Use humidity/humidity range	-10	运行环境温度/湿度 Operating environment temperature/humidity	0°C-45°C (不结冰、不凝露) No freezing, No condensation.
输入电压 Input voltage	220VAC 50Hz	保存环境温度/湿度 Preserve ambient temperature/humidity	-10°C-60°C/ 30-85%RH (不凝露)
外形尺寸 outline dimension	270*240*150mm	外形尺寸 outline dimension	340*243*101.5mm

产品特点 Product features

- 丝网印刷行业 · Screen printing industry
- 扬声器、微型扬声器耳机 · Speaker, micro speaker earphone
- 耳塞行业 · Earplug industry
- 光学透镜行业 · Optical lens industry

产品参数 Technical Parameter

发光面积 (mm) light-emitting area	输送宽带 (mm) Transmission broadband	照射距离 (mm) Irradiation distance MM	波长 (mm) wavelength	光功率密度(W/CM ²) Optical power density
100*100	100	5-100	365/395/405	0-15
300*32	200	5-100	365/395/405	0-15
500*30	200	5-100	365/395/405	0-15



Model: NS.UVGHL

新能源uv固化一体机(定制)

New energy uv curing machine (customized)

Model: NS.FB.2022011501WF



适用产品 Applicable products

产品尺寸: 最大宽度400mm
Product size: maximum width 400mm

功能及特点 Functions and characteristics

- LED灯珠采用进口光UVLED灯珠, 衰减慢寿命长。
- LED灯珠搭配短路、过流、超温等保护功能。
- 光源功率可以独立设定, 并以百分比显示出来, 功率调整精度达到1%。(固化设备启动功率百分比为8-10%)
- 具备自动、手动、阶梯、脉冲等照射模式。
- 配备完善的外部I/O控制接口, 实现与自动化设备的完美连接;
- 触摸式操作面板, 操作简单直观。
- 科学散热结构设计, 确保设备工作温度的正常范围内, 保证光功率恒定输出

- LED lamp bead adopts imported light UVLED lamp bead, which has slow attenuation and long service life.
 - LED lamp beads are equipped with protection functions such as short circuit, overcurrent and overtemperature.
 - The power of light source can be set independently and displayed as a percentage, and the power adjustment accuracy reaches 1%. (The starting power of curing equipment is 100% 8-10%)
 - With automatic, manual, step, pulse and other irradiation modes.
 - Equipped with perfect external I/O control interface to realize perfect connection with automation equipment;
 - Touch operation panel, simple and intuitive operation.
- Scientific heat dissipation structure design to ensure the normal range of equipment working temperature and constant output of optical power.

规格参数 Functions and characteristics

光功率 luminous power	365nm: 900mw/cm ²	(光功率可根据光源功率调节)	(The light power can be adjusted according to the light source power)
传递速度 Transmission speed	0.5-5m/min可调	Optical power density	
照射面积 Irradiated area			
照射距离 Illumination distance	10mm ~ 150mm (手动调节)	(Manual adjustment)	
功耗 power consumption	8350w		
产品温度 Product temperature	≤50°C		
外形尺寸 outline dimension	照射头: 600mm (L) * 200mm (W) * 110mm (H); 输送机: 1600mm (L) * 1100mm (W) * 1515±25mm (H)		
供电规格 Power supply specification	(1) .220VAC/50HZ;	(2) .22.0机器自带2m长电线	Optical power density
传送网带 Conveying belt	不锈钢网带 (网带尺寸: 400X2000)	Stainless steel mesh belt (mesh belt size: 400X2000)	

四轴机器人锁螺丝机

Four-axis robot lock screw machine

>>>C4系列

产品特点 Product features

1. 适应各种锁附面, 模块化设计, 灵活部署, 可快速换产
 2. 锁附过程实时监控, 对比人工效率提升80%以上;
 3. 标配视觉纠偏, 即使工件偏差也能轻松搞定;
 4. 具备产品配方功能, 切换已保存产品时免去重复示教的烦恼;
1. Adapting to various locking surfaces, modular design and flexible deployment, which can quickly change production.
2. Real-time monitoring of locking process, which improves the efficiency by more than 80% compared with labor;
3. Visual deviation correction is standard, even if the workpiece deviation can be easily solved;
4. It has the function of product formula, and avoids the trouble of repeated teaching when switching saved products;

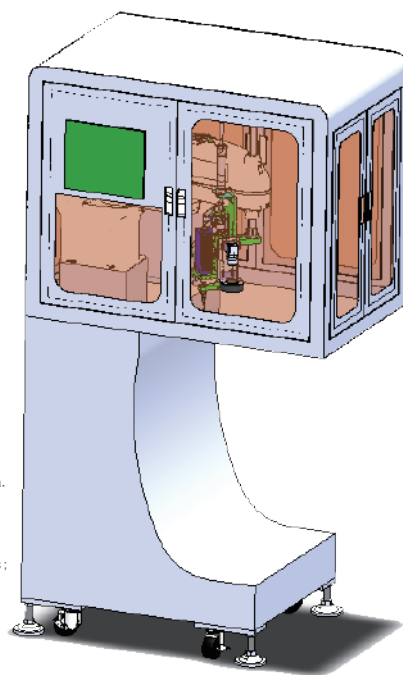

标准配置 standard layout

- 供料器 Feeder
- 伺服电批 Servo batch
- CCD视觉定位 CCD visual positioning
- 安全上罩 CCD visual positioning
- 安全光栅 Security grating

可选配置 Optional configuration

- 真空吸/磁吸/吹气式 Vacuum suction/magnetic suction/blowing type
- 信息扫描 Information scanning
- 智能电批 Intelligent batch

智能拧紧工匠案例 Intelligent tightening craftsman case

- 像招工一样轻松导入 Import as easily as recruitment.
- 轻易插入产线, 灵活部署, 产式多样 Easy to insert into the production line, flexible deployment, and diverse production types.



产品参数 Product parameter

规格型号 specifications and models	NS. SF. SCARA-4
电批型号 Electric batch model	伺服电批 Servo batch
是否标配视觉系统 Is the visual system standard	Yes
供钉方式 Nail supply mode	真空吸/磁吸/吹气式 Vacuum suction/magnetic suction/blowing type
螺钉长径比 Length diameter ratio of screw	螺丝长度 > 1.2倍螺丝帽直径 Screw length-1.2 times the diameter of screw cap
适配螺钉直径 Adapter screw diameter	M1--M5
拧紧扭力范围 Tightening torque range	0.1-9kg
标准循环时间 Standard cycle time	0.3s
螺钉供率效率 Screw feed efficiency	0.5s
拧紧程序是否可以程序控制 Can the tightening procedure be controlled by program?	Yes
扭力是否可以数字显示 Can torque be displayed digitally	Yes
工作范围*2 Scope of work *2	半径600mm
功率 power	2000W
Z轴行程 Z-axis stroke	100mm
是否自带浮高感知 Does it have its own floating height perception?	Yes
是否自带滑牙感知 Does it have sliding tooth perception	Yes

在线式视觉螺丝机

On-line visual screw machine

>>>L4系列

产品特点 Product features

送料方式：磁吸式/吸附式/吹气式（可选）

1. 适应各种锁附面，模块化设计，灵活部署，可快速换产；
2. 锁附过程实时监控，对比人工效率提升80%以上；
3. 标配视觉纠偏，即使工件偏差也能轻松搞定；
4. 具备产品配方功能，切换已保存产品时免去重复示教的烦恼；

Feeding mode: magnetic suction/adsorption/blowing (optional)

1. Adapt to various locking surfaces, modular design, flexible deployment, and quick production change;
2. Real-time monitoring of the locking process improves the efficiency by more than 80% compared with manual work;
3. Standard visual deviation correction, even if the workpiece deviation can be easily fixed;
4. It has the function of product formula, and avoids the trouble of repeated teaching when switching saved products;

标准配置 standard layout

- 供料器 Feeder
- 伺服电批 Servo batch
- CCD视觉定位 CCD visual positioning
- 安全上罩 Safety cover
- 安全光栅 Security grating

可选配置 Optional configuration

- 信息扫描 Information scanning
- 智能电批 Intelligent batch

产品参数 Product parameter

规格型号 specifications and models	NS. SF. SCARA-4/6
电批型号 Electric batch model	伺服电批 Servo batch
是否标配视觉系统 Is the visual system standard	Yes
供钉方式 Nail supply mode	真空吸/磁吸/吹气式 Vacuum suction/magnetic suction/blowing type
螺钉长径比 Length diameter ratio of screw	螺丝长度 > 1.2倍螺丝帽直径 Screw length-1.2 times the diameter of screw cap
适配螺钉直径 Adapter screw diameter	M1--M5
拧紧扭力范围 Tightening torque range	0.1-9kg
标准循环时间 Standard cycle time	0.3s
螺钉供率效率 Screw feed efficiency	0.5s
拧紧程序是否可以程序控制 Can the tightening procedure be controlled by program?	Yes
扭力是否可以数字显示 Can torque be displayed digitally	Yes
工作范围*2 Scope of work *2	半径600mm
功率 power	2000W
Z轴行程 Z-axis stroke	100mm
是否自带浮高感知 Does it have its own floating height perception?	Yes
是否自带滑牙感知 Does it have sliding tooth perception	Yes



在线式六轴双轨螺丝机

On-line six-axis double-track screw machine

>>>P9系列

产品特点 Product features

送料方式：磁吸式/吸附式/吹气式（可选）

1. 在线式双头轨道锁附，宽道可调；
2. 产品可夹道式流入设备轨道，自动完成产品定位及锁附；
3. 智能检测漏锁、浮锁、滑牙、浮高以及自动记录浮高坐标；
4. 可连接WLAN网络，访问MES系统，配置win10系统；

Feeding mode: magnetic suction/adsorption/blowing (optional)

1. On-line double-head rail locking, adjustable width;
2. The product can flow into the equipment track in a tunnel way, and the product positioning and locking can be automatically completed;
3. Intelligent detection of missing lock, floating lock, sliding tooth and floating, recording floating coordinates;
4. You can connect to WLAN network, access MES system and configure win10 system;

标准配置 standard layout

- 供料器 Feeder
- 伺服电批 Servo batch
- 安全上罩 Safety cover
- 安全光栅 Security grating

可选配置 Optional configuration

- 信息扫描 Information scanning
- 智能电批 Intelligent batch
- CCD视觉定位 CCD visual positioning

产品参数 Product parameter

产品型号 product model	NS. SF. 9551A-PL-2T
运动轴数 Motion axis number	六轴 (XXYYZZ)
锁附范围 Locking range	350*300*100 (x*y*z)
直线导轨 Linear guide	上银/THK/银泰 Shangyin//THK//yintai
定位精度 positioning accuracy	±0.02mm
控制系统 control system	多轴运动控制卡+PC上位机 Multi-axis motion control card+PC host computer
送料方式 Feeding mode	吸附式/磁吸式 Adsorption/magnetic attraction
供料器数量 Number of feeders	2/4组
锁附效率 Locking efficiency	1~1.5S/PCS
通讯方式 communication method	232/485
输入电源 Input power supply	AC220V 50Hz
功率 power	AC220V /800W
输入气压 Input air pressure	0.4-0.6MPa
设备功率 Equipment power	1.5KW
外形尺寸 outline dimension	(L*W*H) 1530*1300*2000mm
本体重量 Body weight	220KG



在线式双轨双头锁螺丝机（皮带式）

On-line double-track double-head locking screw machine (belt type)

>>>P6系列

产品特点 Product features

送料方式：磁吸式/吸附式/吹气式（可选）

1. 适应各种锁附面，模块化设计，灵活部署，可快速换产；
2. 锁附过程实时监控，对比人工效率提升80%以上；
3. 标配视觉纠偏，即使工件偏差也能轻松搞定；
4. 具备产品配方功能，切换已保存产品时免去重复示教的烦恼；

Feeding mode: magnetic suction/adsorption/blowing (optional)

1. Adapt to various locking surfaces, modular design, flexible deployment, and quick production change;
2. Real-time monitoring of the locking process improves the efficiency by more than 80% compared with manual work;
3. Standard visual deviation correction, even if the workpiece deviation can be easily fixed;
4. It has the function of product formula, and avoids the trouble of repeated teaching when switching saved products;



标准配置 standard layout

- 供料器 Feeder
- 伺服电批 Servo batch
- CCD视觉定位 CCD visual positioning
- 安全上罩 Safety cover
- 安全光栅 Security grating

可选配置 Optional configuration

- 信息扫描 Information scanning
- 智能电批 Intelligent batch

产品参数 Product parameter

产品型号 product model	NS. SF. 5577-PL-LD
锁附范围 Locking range	350*300*100 (x*y*z)
传动方式 Transmission mode	皮带+电机 Belt+motor
直线导轨 Linear guide	上银/THK/银泰 Shangyin/THK/yintai
定位精度 positioning accuracy	±0.02mm
控制系统 control system	多轴运动控制卡+PC上位机
供料方式 Feeding mode	吸附式/磁吸式 Adsorption/magnetic attraction
供料器数量 Number of feeders	2组
锁附效率 Locking efficiency	1~1.5S/PCS
通讯方式 communication method	232/485
输入电源 Input power supply	AC220V 50Hz
功率 power	AC220V /800W
输入气压 Input air pressure	0.4-0.6MPa
设备功率 Equipment power	1.5KW
外形尺寸 outline dimension	(L*W*H) 1176*1200*1645mm
本体重量 Body weight	

离线式双工位自动锁螺丝机

Floor-standing double-station automatic locking screw machine

>>>F6 II 系列

产品特点 Product features

送料方式：磁吸式/吸附式/吹气式（可选）

1. 双头双工位交替式作业，可独立锁付；
2. 机器可长时间24小时工作不停机，高效率生产；
3. 设备可根据客户需求上传MES，如扭力、圈数、角度、扭力曲线图、锁付状态。

Feeding mode: magnetic suction/adsorption/blowing (optional)

1. Double-head and double-station alternate operation, which can be locked and paid independently;
2. The machine can work for 24 hours without stopping for a long time, and the production is efficient;
3. The equipment can upload MES according to customer's requirements, such as torque, number of turns, angle, torque graph and locked payment status.



标准配置 standard layout

- 供料器 Feeder
- 伺服电批 Servo batch
- 安全上罩 Safety cover
- 安全光栅 Security grating

可选配置 Optional configuration

- 信息扫描 Information scanning
- 智能电批 Intelligent batch
- CCD视觉定位 CCD visual positioning

产品参数 Product parameter

产品型号 product model	NS. SF. 62TD
锁附范围 Locking range	1300*1500*1800 (L*W*H)
传动方式 Transmission mode	500*400*200 (X*Y*Z)
直线导轨 Linear guide	伺服电机+丝杆模组 Servo motor+screw module
定位精度 positioning accuracy	±0.02mm
控制系统 control system	PC/PLC+多轴运动控制卡 Pc/PLC+multi-axis motion control card
供料方式 Feeding mode	吸附式/磁吸式 Adsorption/magnetic attraction
供料器数量 Number of feeders	2组
锁附效率 Locking efficiency	1-2S/PCS
通讯方式 communication method	支持MES系统连接 Support MES system connection
输入电源 Input power supply	AC220V 50Hz
功率 power	AC220V /2000W
输入气压 Input air pressure	0.4-0.6MPa
设备功率 Equipment power	2KW
本体重量 Body weight	300KG

离线式视觉四轴大行程螺丝机

Off-line vision four-axis large-stroke screw machine

>>>F12系列

产品特点 Product features

送料方式:磁吸式/吸附式/吹气式(可选)

1. 智能检测痛锁、浮锁、滑牙、浮高以及自动记录浮高坐标;
2. 可连接WLAN网络,访问MES系统,配置win10系统;
3. 增加自动沾胶功能系统,螺丝沾胶锁螺丝;

Feeding mode: magnetic suction/adsorption/blowing (optional)

1. Intelligent detection of pain lock, floating lock, sliding tooth, floating height aof floating height
2. You can connect to WLAN network, access MES system and configure win10 system;
3. An automatic gluing function system is added, and the screws are glued to lock the screws;



沾胶功能系统

Glue-dipping functional system



标准配置 standard layout

- 供料器 Feeder
- 伺服电批 Servo batch
- CCD视觉定位 CCD visual positioning
- 安全上罩 Safety cover
- 安全光栅 Security grating

可选配置 Optional configuration

- 信息扫描 Information scanning
- 智能电批 Intelligent batch

产品参数 Product parameter

产品型号 product model	NS. S F. 1216HE-2TP L-B
锁附范围 Locking range	1000*1200*200m m (X*Y*Z)
直线导轨 Linear guide	上银/THK/银泰 Shangyin//THK//yintai
重复精度 repeatability	±0.02mm
操作模式 operator schema	视觉定位、检测 Visual positioning and visual detection
供料方式 Feeding mode	吸附式/磁吸式 Adsorption/magnetic attraction
编程模式 Programming mode	触摸屏显示器 touch screen
输入电源 Input power supply	AC220V / 50-60Hz 1.4kw
工作环境温度湿度 Working environment humidity	5-40° C/20%-90%
外形尺寸 outline dimension	L1790*W1380*H1820

离线式六轴螺丝机

Off-line six-axis screw machine

>>>F8系列

产品特点 Product features

送料方式:磁吸式/吸附式/吹气式(可选)

1. 支持深孔、斜孔、弧面、高低不一样的面, 不锈钢螺丝, 介子螺丝;
2. 智能伺服电批可支持一个产品锁付三种不一样的扭力;
3. 智能检测痛锁、浮锁、滑牙、浮高以及自动记录浮高坐标;
4. 柜式结构, 外观高端大气。顶棚带灯, 前后带光栅, 操作安全可靠;

Feeding mode: magnetic suction/adsorption/blowing (optional)

1. Support deep holes, inclined holes, cambered surfaces, surfaces with different heights, stainless steel screws and meson screws;
2. Intelligent servo batch can support one product to lock and pay three different torques;
3. Intelligent detection of painful lock, floating lock, sliding tooth and floating height, and automatic recording of floating height coordinates;
4. Cabinet structure with high-end atmosphere. The ceiling is equipped with lights, and the front and back are equipped with gratings, so the operation is safe and reliable;



标准配置 standard layout

- 供料器 Feeder
- 伺服电批 Servo batch
- 安全上罩 Safety cover
- 安全光栅 Security grating

可选配置 Optional configuration

- 信息扫描 Information scanning
- 智能电批 Intelligent batch
- CCD视觉定位 CCD visual positioning

产品参数 Product parameter

产品型号 product model	NS. SF. 6688-2TOL-A/B
设备行程 Equipment travel	640mm*800mm*100mm(X*Y*Z)
锁附范围 Lock payment range	200mm*350mm(单Y平台)四工位 220*680mm (single Y platform) four stations
直线导轨 Linear guide	上银/THK/
定位精度 positioning accuracy	±0.02mm
控制系统 control system	多轴运动控制卡+触摸屏 Multi-axis motion control card+touch screen
供料方式 Feeding mode	吸附式/磁吸式 Adsorption/magnetic attraction
供料器数量 Number of feeders	2组
锁附效率 Locking efficiency	1~1.5S/PCS
程序容量 Program capacity	100组
输入电源 Input power supply	AC220V 50Hz
功率 power	AC220V /800W
输入气压 Input air pressure	0.4-0.6MPa
外形尺寸 outline dimension	(L*W*H) 1030mm*900mm*1650mm
本体重量 Body weight	200KG

离线式六轴视觉螺丝机

Off-line six-axis vision screw machine

>>>F5系列



产品特点 Product features

送料方式:磁吸式/吸附式/吹气式(可选)

1. 配置双工位双批头双CCD视觉定位, 可同时锁附相同产品;
2. 人机界面控制、速度、转速等参数可调, 具有自动生产计数功能;
3. 智能检测漏锁、浮锁、滑牙、浮高以及自动记录浮高坐标;
4. 可连接WLAN网络, 访问MES系统, 配置win10系统;

Feeding mode: magnetic suction type/adsorption type/air blowing type (optional)

1. Equipped with double-station double-batch head and double CCD visual positioning, at the same time;
2. Man-machine interface control, adjustable speed, rotational speed and other parameters, with automatic production counting function;
3. Intelligent detection of missing lock, floating lock, sliding tooth and floating height, and automatic of floating height coordinates;
4. You can connect to WLAN network, access MES system and configure win10 system;

标准配置 standard layout

- 供料器 Feeder
- 伺服电批 Servo batch
- 安全上罩 Safety cover
- 安全光栅 Security grating

可选配置 Optional configuration

- 信息扫描 Information scanning
- 智能电批 Intelligent batch
- CCD视觉定位 CCD visual positioning

产品参数 Product parameter

产品型号 product model	NS.SF.5331EA-OL-2T
设备行程 Equipment travel	1020*870*100mm (X*Y*Z)
锁附范围 Lock payment range	220*680mm(单Y平台)四工位 220*680mm (single Y platform) four stations
直线导轨 Linear guide	上银/THK/
定位精度 positioning accuracy	±0.02mm
控制系统 control system	多轴运动控制卡+触摸屏 Multi-axis motion control card+touch screen
供料方式 Feeding mode	吸附式/磁吸式 Adsorption/magnetic attraction
供料器数量 Number of feeders	1/2组
锁附效率 Locking efficiency	1~1.5S/PCS
程序容量 Program capacity	100组
输入电源 Input power supply	AC220V 50Hz
功率 power	AC220V /800W
输入气压 Input air pressure	0.4-0.6MPa
外形尺寸 outline dimension	(L*W*H)1030*900*190mm
本体重量 Body weight	200KG

在线式螺丝机应用案例

Application case of on-line screw machine

- 适用于小螺丝、高精度锁付；针对手机，耳机，智能手表3C等消费电子；
- 适用于产品上有较大数量螺丝、高扭矩的锁付；针对滤波器，无人机中框，平板电脑，家电等；

Suitable for small screws and high-precision locking; For mobile phones, headphones, smart watches 3C and other consumer electronics; Suitable for locking with a large number of screws and high torque on the product; For filters, UAV middle frames, tablet computers, home appliances, etc.

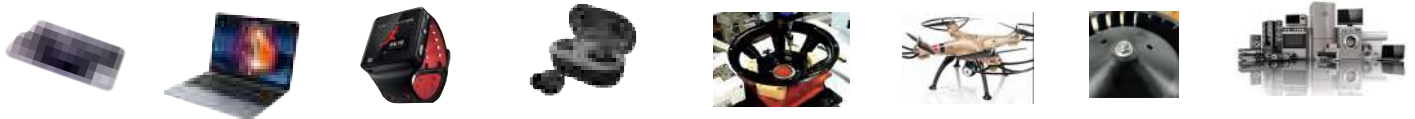

在线式自动锁螺丝机器人解决方案

On-line automatic screw locking robot solution



左进右出大行程自动锁螺丝机器人解决方案

Solution of large stroke automatic screw locking robot with left entry and right exit

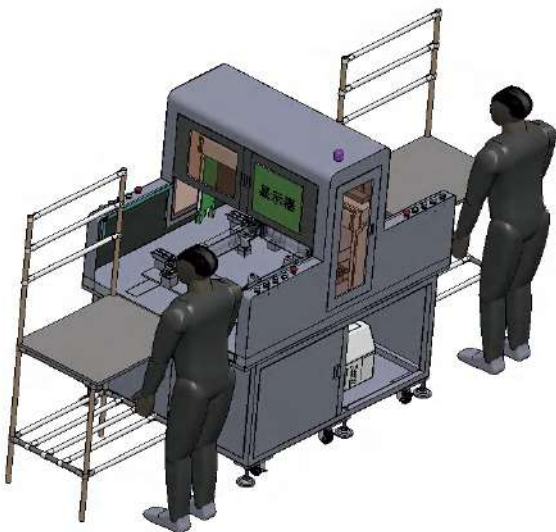

沾胶功能系统
Glue-dipping functional system



在线式机器人自动锁螺丝机解决方案

Solution of online robot automatic locking screw machine

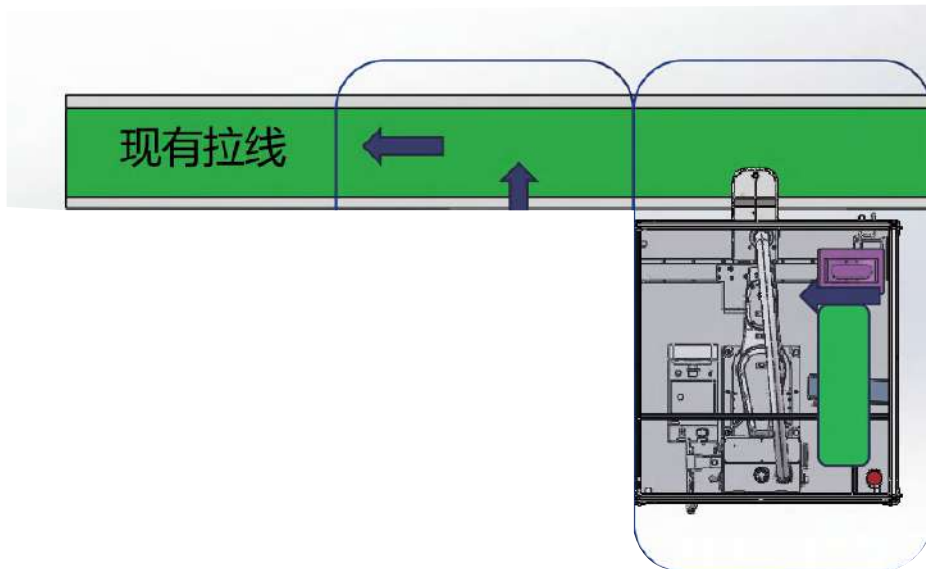

在线式智能制造整体解决方案

Overall solution of on-line intelligent manufacturing



精密锁付螺丝机系列

六轴双Y螺丝机

Six-axis double Y screw machine

>>>Screw T7系列

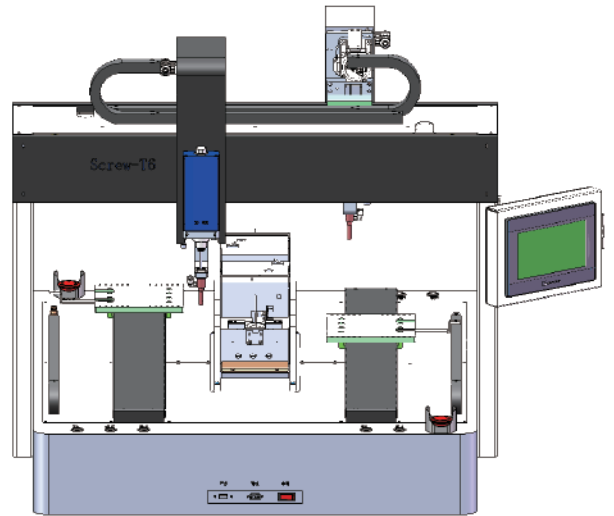

产品特点 Product features

送料方式: 磁吸式/吸附式/吹气式(可选)

1. 可以兼并多种螺丝锁附工艺;
2. 六轴背靠背双平台, 双头锁附, 可交替作业, 效率倍增;
3. 智能检测漏锁、浮锁、滑牙、浮高以及自动记录浮高坐标;
4. 搭载自主研发运动控制卡, 傻瓜式编程, 触屏显示扭力、锁附效率!

Feeding mode: magnetic suction/adsorption/blowing (optional)

1. Various screw locking processes can be merged;
2. Six-axis back-to-back double platforms and double-head locking attachment, which can work alternately and double the efficiency;
3. Intelligent detection of missing lock, floating lock, sliding tooth and floating height, height coordinates;
4. Equipped with self-developed motion control card, fool-like programming, touch screen display torque and locking efficiency!

标准配置 standard layout

- 供料器 Feeder
- 伺服电批 Servo batch

可选配置 Optional configuration

- 信息扫描 Information scanning
- 智能电批 Intelligent batch
- CCD视觉定位 CCD visual positioning
- 安全上罩 Safety cover
- 安全光栅 Security grating

产品参数 Product parameter

产品型号 product model	NS. SF. 5577-2TD-A/B
设备行程 Equipment travel	640mm*800mm*100mm(X*Y*Z)
锁附范围 Lock payment range	200mm*350mm(单Y平台) 四工位 220*680mm (single Y platform) four stations
直线导轨 Linear guide	上银/THK/
定位精度 positioning accuracy	±0.02mm
控制系统 control system	多轴运动控制卡+触摸屏 Multi-axis motion control card+touch screen
供料方式 Feeding mode	吸附式/磁吸式 Adsorption/magnetic attraction
供料器数量 Number of feeders	2组
锁附效率 Locking efficiency	1~1.5S/PCS
程序容量 Program capacity	100组
输入电源 Input power supply	AC220V 50Hz
功率 power	AC220V /800W
输入气压 Input air pressure	0.4-0.6MPa
外形尺寸 outline dimension	(L*W*H) 1130mm*780mm*800mm
本体重量 Body weight	90Kg

六轴双Y螺丝机

Six-axis double Y screw machine

>>>Screw T6系列

产品特点 Product features

送料方式:磁吸式/吸附式/吹气式(可选)

1. 支持深孔、斜孔、弧面、高低不一样的面, 不锈钢螺丝, 介子螺丝;
2. 智能检测漏锁、浮锁、滑牙、浮高以及自动记录浮高坐标;
3. 搭载自主研发运动控制卡, 傻瓜式编程, 触屏显示扭力、锁附效率;
4. 双Y轴平台交替作业, 节省产品取放时间, 实现生产效率最大化, 适用于产品上面有不同型号的螺丝;

Feeding mode: magnetic suction/adsorption/blowing (optional)

1. Support deep holes, inclined holes, cambered surfaces, surfaces with different heightscrews;
2. Intelligent detection of missing lock, floating lock, sliding tooth and floating floating height coordinates;
3. Equipped with self-developed motion control card, fool-like programming, touch screen display torque and locking efficiency;
4. Double Y-axis platforms work alternately, which saves the time for taking and placing products and maximizes the production efficiency, and is suitable for products with different types of screws;



标准配置 standard layout

- 供料器 Feeder
- 伺服电批 Servo batch

可选配置 Optional configuration

- 信息扫描 Information scanning
- 智能电批 Intelligent batch
- CCD视觉定位 CCD visual positioning
- 安全上罩 CCD visual positioning
- 安全光栅 Security grating

产品参数 Product parameter

产品型号 product model	NS. SF. 6644-TD-A/B
设备行程 Equipment travel	600mm*420mm*100mm(X*Y*Z)
锁附范围 Lock payment range	200mm*350mm(单Y平台)四工位 220*680mm (single Y platform) four stations
直线导轨 Linear guide	上银/THK/
定位精度 positioning accuracy	±0.02mm
控制系统 control system	多轴运动控制卡+触摸屏 Multi-axis motion control card+touch screen
供料方式 Feeding mode	吸附式/磁吸式 Adsorption/magnetic attraction
供料器数量 Number of feeders	2组
锁附效率 Locking efficiency	1~1.5S/PCS
程序容量 Program capacity	100组
输入电源 Input power supply	AC220V 50Hz
功率 power	AC220V /800W
输入气压 Input air pressure	0.4-0.6MPa
外形尺寸 outline dimension	(L*W*H) 1100mm*730mm*750mm
本体重量 Body weight	90KG

四轴双Y螺丝机

Our-axis double y fscrew machine

>>>Screw T4系列

产品特点 Product features

送料方式:磁吸式/吸附式/吹气式(可选)

1. 支持深孔、斜孔、弧面、高低不一样的面, 不锈钢螺丝, 介子螺丝;
2. 智能检测漏锁、浮锁、滑牙、浮高以及自动记录浮高坐标;
3. 搭载自主研发运动控制卡, 傻瓜式编程, 触屏显示扭力、锁附效率;
4. 双Y轴平台交替作业, 节省产品取放时间, 实现生产效率最大化, 适用于产品上面有不同型号的螺丝:

Feeding mode: magnetic suction/adsorption/blowing (optional)

1. Support deep holes, inclined holes, cambered surfaces, surfaces with different heights, stainless steel;
2. Intelligent detection of painful locks, floating locks, sliding teeth, floating height and floating height coordinates;
3. Equipped with self-developed motion control card, fool-like programming, touch screen display torque and locking efficiency;
4. Double Y-axis platforms work alternately, saving product picking and placing time and maximizing, suitable for products with different types of screws;

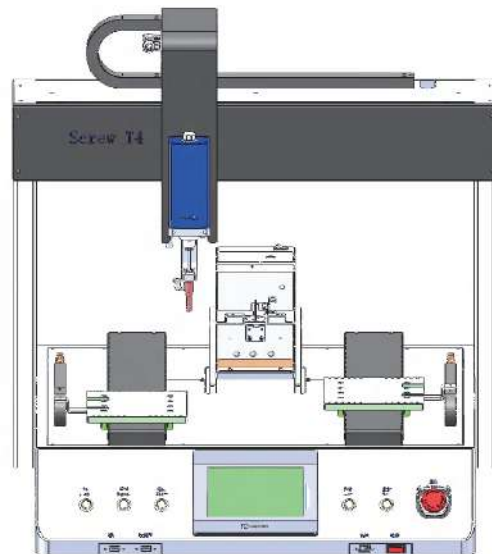

标准配置 standard layout

- 供料器 Feeder
- 伺服电批 Servo batch

可选配置 Optional configuration

- 信息扫描 Information scanning
- 智能电批 Intelligent batch
- CCD视觉定位 CCD visual positioning
- 安全上罩 CDD visual positioning
- 安全光栅 Security grating

产品参数 Product parameter

产品型号 product model	NS. SF. 5441-D-A/B	NS. SF. 6441-D-A/B
设备行程 Equipment travel	550mm*420mm*100mm(X*Y*Z)	650mm*420mm*100mm(X*Y*Z)
锁附范围 Locking range	195mm*350mm(单Y平台)双工位	
直线导轨 Linear guide	上银/THK/	
定位精度 positioning accuracy	±0.02mm	
控制系统 control system	多轴运动控制卡+触摸屏 Multi-axis motion control card+touch screen	
供料方式 Feeding mode	吸附式/磁吸式 Adsorption/magnetic attraction	
供料器数量 Number of feeders	2组	
锁附效率 Locking efficiency	1~1.5S/PCS	
程序容量 Program capacity	100组	
输入电源 Vinput power supply	AC220V 50Hz	
功率 power	AC220V /800W	
输入气压 Input air pressure	0.4-0.6MPa	
外形尺寸 outline dimension	(L*W*H) 730mm*700mm*760mm	(L*W*H) 730mm*800mm*760mm
本体重量 Body weight	60KG	70KG

迷你型螺丝机

Miniature screw machine

>>>Screw T2系列

产品特点 Product features

送料方式:磁吸式/吸附式/吹气式(可选)

1. 支持深孔、斜孔、弧面、高低不一样的面, 不锈钢螺丝, 介子螺丝;
2. 智能检测漏锁、浮锁、滑牙、浮高以及自动记录浮高坐标;
3. 搭载自主研发运动控制卡, 傻瓜式编程, 触屏显示扭力、锁附效率;
4. 机身尺寸小, 锁螺丝效率高, 可配双供料器同时打两种螺丝;

Feeding mode: magnetic suction/adsorption/blowing (optional)

1. Support deep holes, inclined holes, cambered surfaces, surfaces with different heights, stainless steel screws;
2. Intelligent detection of missing lock, floating lock, sliding tooth and floating height and automatic recording ;
3. Equipped with self-developed motion control card, fool-like programming, touch screen display torque efficiency;
4. The machine body is small in size and high in screw locking efficiency, and it can be equipped with double feeders to play two kinds of screws at the same time;

标准配置 standard layout

- 供料器 Feeder
- 伺服电批 Servo batch

可选配置 Optional configuration

- 信息扫描 Information scanning
- 智能电批 Intelligent batch
- CCD视觉定位 CCD visual positioning
- 安全上罩 CCD visual positioning
- 安全光栅 Security grating

产品参数 Product parameter

产品型号 product model	NS. SF. 221-D-A/B
设备行程 Equipment travel	230mm*240mm*100mm(X*Y*Z)
锁附范围 Locking range	200mm*200mm(单Y平台)单工位
直线导轨 Linear guide	上银/THK/
定位精度 positioning accuracy	±0.02mm
控制系统 control system	多轴运动控制卡+触摸屏 Multi-axis motion control card+touch screen
送料方式 Feeding mode	吸附式/磁吸式 Adsorption/magnetic attraction
供料器数量 Number of feeders	2组
锁附效率 Locking efficiency	1~1.5S/PCS
程序容量 Program capacity	100组
输入电源 Vinput power supply	AC220V 50Hz
功率 power	AC220V /800W
输入气压 Input air pressure	0.4-0.6MPa
外形尺寸 outline dimension	(L*W*H) 520mm*500mm*690mm
本体重量 Body weight	45Kg



可搭配流水线机械手应用

螺丝机批头耗材

Screwdriver screwdriver consumables

磁性批头 规格齐全

Magnetic batch head has complete specifications.

- 咬合紧 Tight bite
- 高扭矩 High torque
- 磁性强 Strong magnetism



ZERO ONE
LOCK PAYMENT

批头选型示意图

Schematic diagram of batch head selection

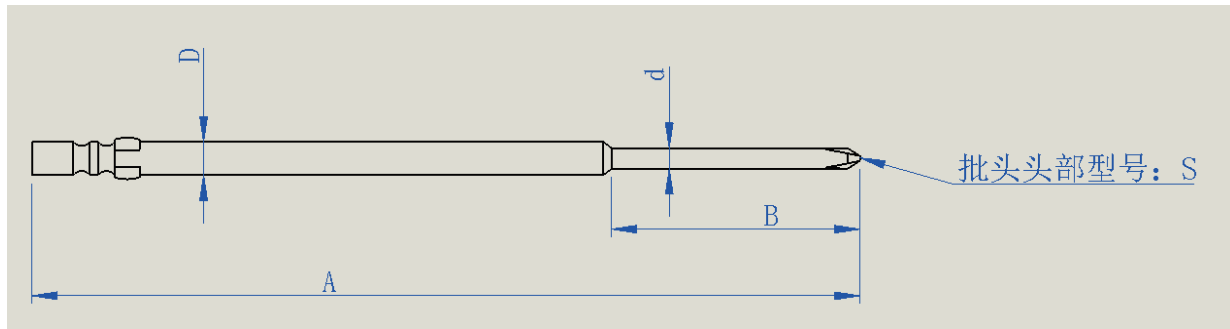

N	S	—	D	*	A	*	d	B	*	s
纳声标识 Nasheng signs			电批安装口径 Electric batch installation caliber Ø4 / Ø5		批头: 总长 Head: chief 常用: 80/100/120		批头缩小部分直径 Diameter of narrowed part of batch head 常用: Ø1.7/2.0/2.5/3.0	批头缩小部分长度 Shortened part length of batch head 常用: 25/30/35/40		头部样式: 以下常用款 Head style: the following commonly used models 十字: 00#/0#/1#/2# 梅花: T4/T5/T8/T10

批头型号确认:

1. 依螺丝头确认批头头部样式:
2. 00#批头最为尖细, 2#最为钝和粗, 批头插入螺丝头槽内, 用手轻力晃动螺丝, 摆动幅度小稳即为匹配OK
3. 确认批头长度: 产品螺丝在同一平面且为浅孔的一般80或100长, 深孔120或120以上

Type confirmation of batch head:

1. Confirm the batch head style according to the screw head: 2.00 # batch head is the thinnest, and 2 # batch head is the dullest and thicker. Insert the batch head into the screw head groove, and shake the screw lightly with your hand, so that the swing amplitude is small and stable, which means it matches OK
3. Confirm the batch head length: the product screws are in the same plane and are generally 80 or 100 long for shallow holes, and 120 or more for deep holes.

柔性上料工作站

Flexible feeding workstation



产品介绍 Product introduction

柔性生产，便捷切换生产不同品类产品，快速在客户各类生产场景中应用实施，可选配不同品牌规格的 SCARA 机器人，不同规格的供料器、储料仓，极具竞争力的综合成本：免于集成的差错和时间成本，一体化集成储料仓、柔性振动盘、视觉定位系统和机器人抓取系统，可根据客户产品形状尺寸、产能要求，定制化机械手末端设计——弗莱克斯多达 3000+上料应用。

Flexible production, convenient switching to produce different kinds of products, rapid application and implementation in various production scenarios of customers, optional SCARA robots with different brands and specifications, feeders and storage bins with different specifications, highly competitive comprehensive cost: free of integration errors and time costs, integrated storage bins, flexible vibrating plates, visual positioning systems and robot grasping systems, and end-to-end design can be made according to the product shape, size and capacity requirements of customers—as many as 300 in Flex.

高端应用 High end application

适用于各类细小物料的 摆盘、上料、分拣作业、移动方便；

Suitable for setting, feeding and sorting all kinds of fine materials, and easy to move;



在线式视觉对位贴合机

On-line visual alignment laminating machine

产品特点 Product features

1. 高效率，精度高，Y轴采用2组直线电机分别配置1组贴装头及1组复检CCD，交错动作；
2. 防重贴、防漏贴技术，有效提高产品良率，减少报废；
3. 配备MES功能，可根据客户MES文档做数据上传；
4. CCD取料可精准定位，并适应到最小2*2mm的辅料；

1. High efficiency and precision. Two groups of linear motors are used in the Y-axis, and one group of mounting CCD are respectively configured for staggered action;
2. Anti-re-pasting and anti-leakage pasting technology can effectively improve the product yield and reduce scrap;
3. Equipped with MES function, data can be uploaded customer MES documents;
4. CCD material can be accurately positioned to the minimum 2*2mm auxiliary materials;

高端应用 High end application

应用于3C电子，智能手机、手表，平板电脑等领域；

Used in 3C electronics, smart phones, watches, tablet computers and other fields;



产品参数 Product parameter

产品名称 product model	在线式视觉对位贴合机 On-line visual alignment laminating machine
运动范围 Range of motion	(X/Y/Z) 750*2/200/50mm
最大负载 maximum load	(X 轴) 20KG
重复精度 repeatability	±0.01mm
作业高度 Working height	地面到轨道皮带高度：950mm(可调) Height of belt from ground to track: 950mm (adjustable)
驱动方式 type of drive	直线电机 linear motion actuator
传动方式 Transmission mode	伺服电机+丝杆模组+同步带模组+直线电机 Servo motor+screw module+synchronous belt module+linear motor
操作模式 operator schema	工业控制电脑+PLC Industrial control computer++PLC
编程模式 Programming mode	键鼠+显示器+触摸屏 Mouse and keyboard+monitor+touch screen
视觉分辨率 Visual resolution	0.01*0.01mm/Pixel(可调)
识别范围/光源 Identification range/light source	25*25mm/LED 条形，同轴光源（通讯协议自动调光） 25 * 25mm/LED strip, coaxial light source (communication protocol automatic dimming)
功率/输入电源 Power/input power supply	2000W/AC 110V/220V(内部切换) 50-60HZ
工作环境温度湿度 Working environment temperature and humidity	5-40℃/20-90%不结露
外形尺寸/本体重量(kg) Overall dimension/body weight (kg)	L1400*W1480*H1800mm/约2000kg

微焊接设备系列

Micro welding equipment series

激光焊、点焊、加锡、焊锡设备

Laser welding, spot welding, tin adding and soldering equipment

专用软件，操作简单，功能强大，拓展性强，超高性价比

Special software, simple operation, powerful function, strong expansibility and super high price comparison

产品特点Features

丰富种类:

Rich variety:

多样化的微焊接种类，从激光焊、点焊、加锡、焊锡多样化的应用平台，满足行业各种应用工艺；

Diversified types of micro-welding, from laser welding, spot welding, tin adding and soldering, meet various application processes in the industry;

强大的系统功能:

Powerful system functions:

从三轴应用到八轴应用，从简单的自动微焊接到智能视觉识别功能，以简单、实用方式呈现，使设备操作更人性化；

From three-axis application to eight-axis application, from simple automatic micro-welding to intelligent visual recognition function, it is presented in a simple and practical way, which makes the equipment operation more humanized;

机器性能:

Machine performance:

1. 可选配CCD视觉识别系统，可精确定位，视觉纠偏，提高编程效率和焊锡精度；

2. 性能稳定，配置丰富，拓展性广，能适应复杂表面；

3. 可省50%人力；

1. CCD visual identification system can be selected, which can accurately locate and visually correct deviation, and improve programming efficiency and tin precision;

2. Stable performance, rich configuration, wide expansibility, adaptability to complex surfaces,

3. 50% labor saving;

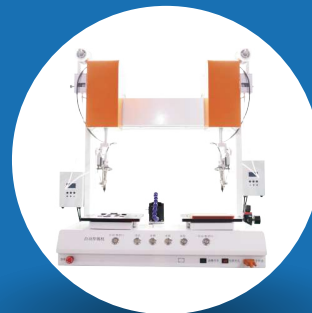

微焊接机选型篇

Micro welding machine selection

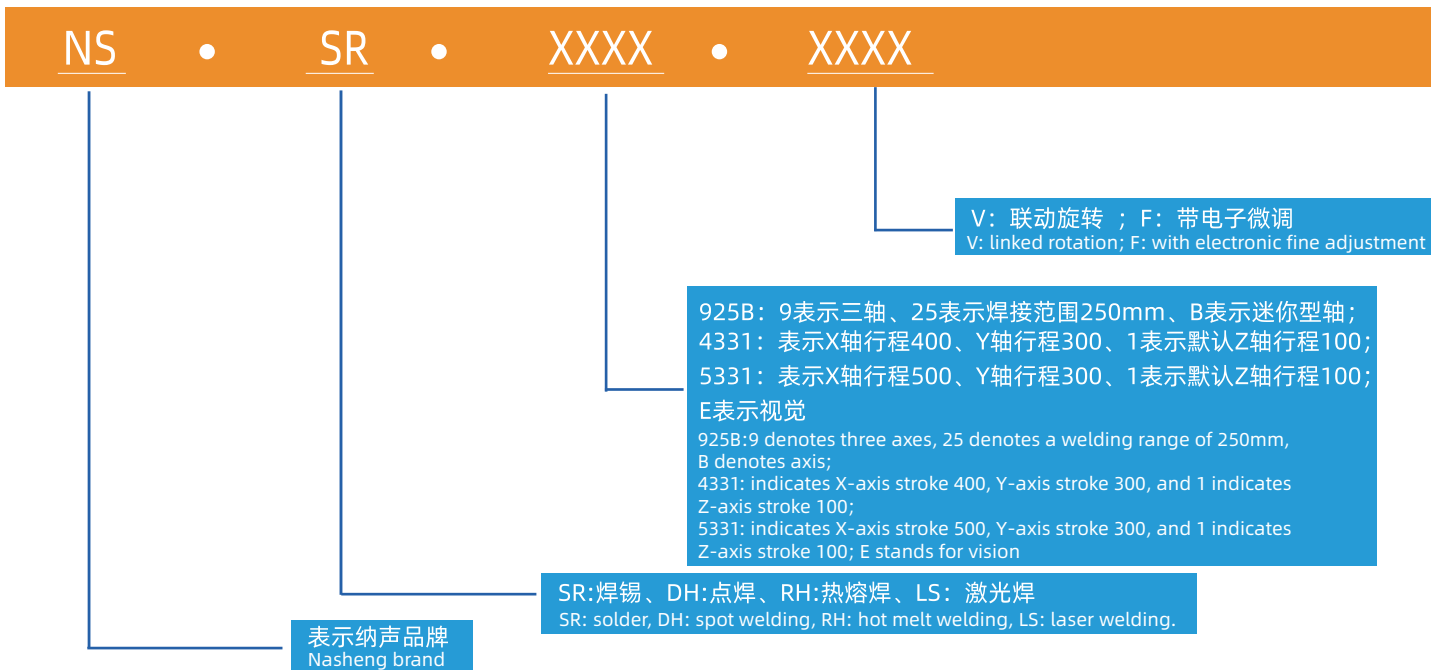

举例及说明

微焊接应用领域 Micro welding application areas

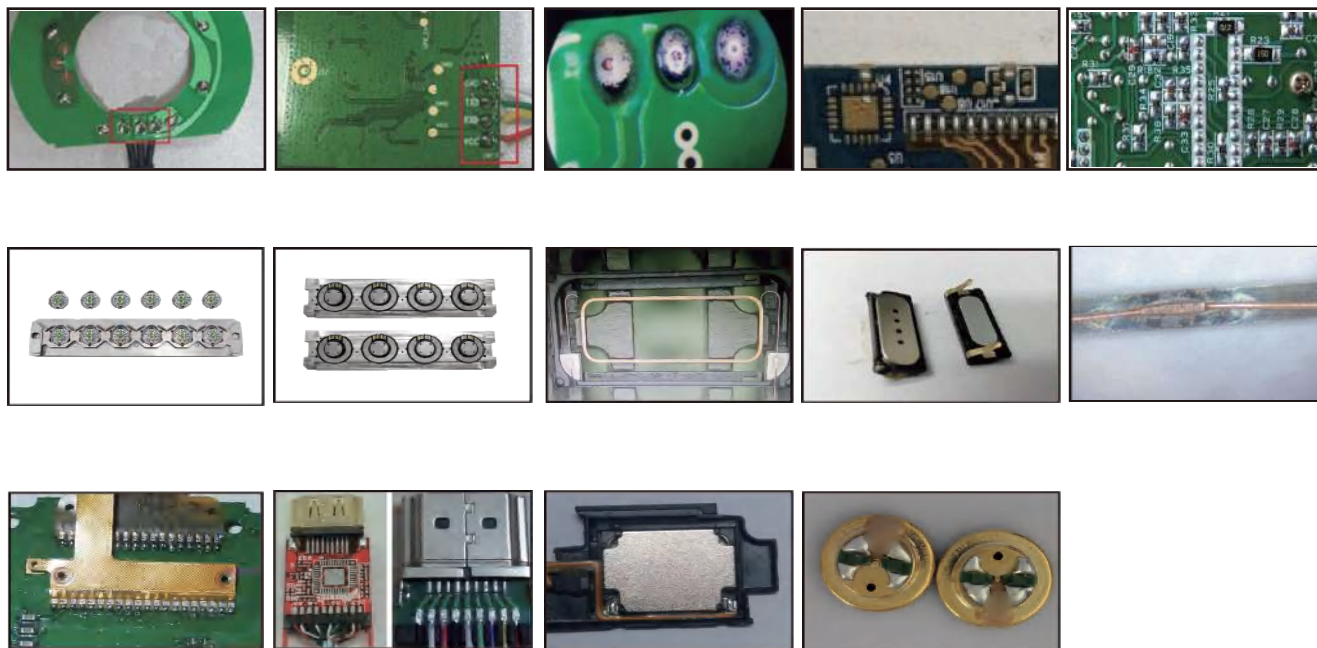

精密视觉三轴喷锡球

Precision vision three-axis tin spraying ball

型号: NS.SP.920HE/930HE

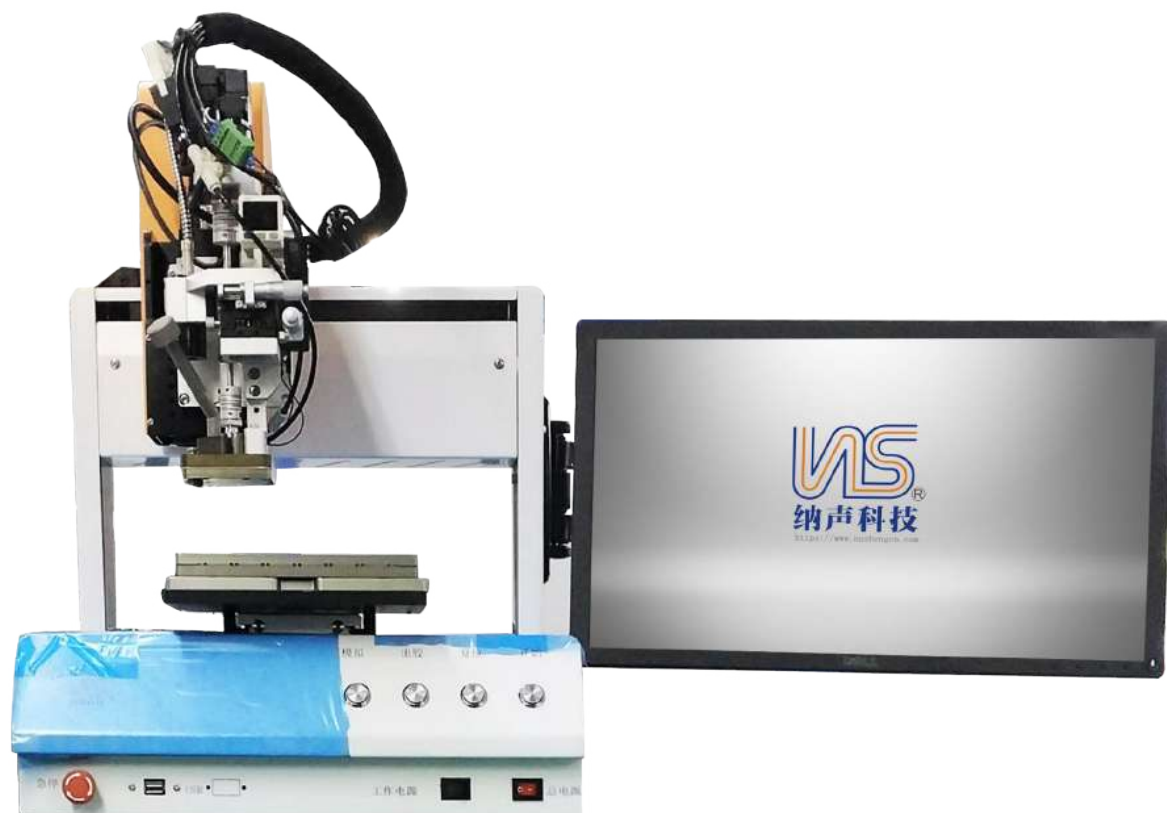

自动微焊接机器人系列

产品特点

Features

1. 智能视觉点胶系统，配合MARK 拍照实时定位纠正点胶轨迹，引导点胶；
 2. 满足窄边框和狭小空间点胶；
 3. 搭载喷射阀功能模块，非接触式点胶，实现更小的点胶直径，也可搭载其他点胶阀方式，以及更广的适用领域；
 4. 可实现0.25mm的稳定胶线宽或胶点直径；
1. Intelligent vision dispensing system, which coordinates with MARK to take photos, position and correct real time, and guide dispensing;
 2. Meet the requirements of dispensing glue in narrow borders and narrow spaces;
 3. Equipped with injection valve function module and non-contact dispensing to realize smaller dispensing diameter, and can also be equipped with other dispensing valves and wider application fields;
 4. Stable glue line width or glue dot diameter of 0.25mm can be realized;

基础配置

Basic configuration

- 三轴运动平台 • 视觉系统
- Three-axis motion platform visual system

客户需求应用案例

Apply customer demand cases

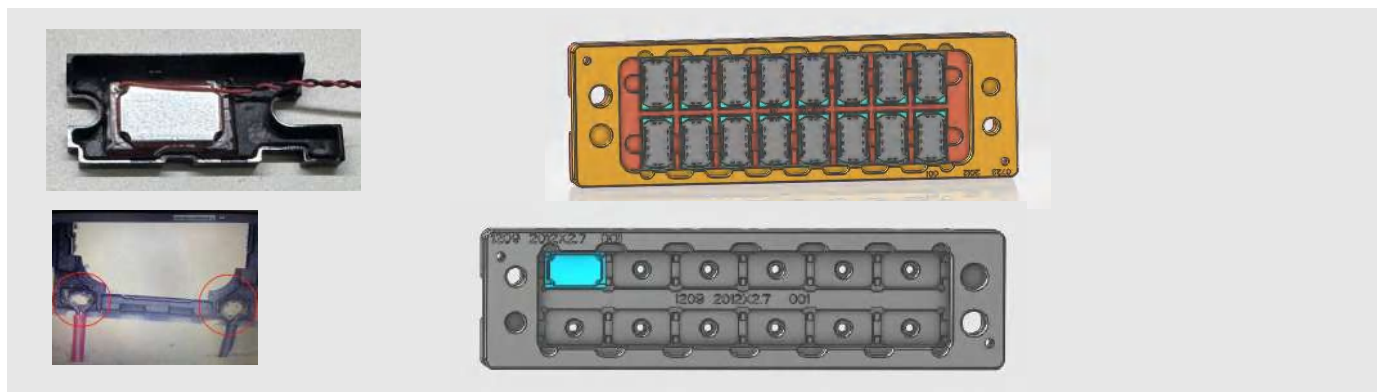

技术参数 technical parameter

产品名称 product name		精密视觉三轴喷锡球 Precision vision three-axis tin spraying ball	
产品型号 product model	NS-SP-920HE	NS-SP-930HE	
运动范围 Range of motion	(X/Y/Z 轴) 200/200/100mm	(X/Y/Z 轴) 300/300/100mm	
最大负载 maximum load	(Y/Z 轴) 8Kg/4Kg (最高速度不能最高负载) (Y/Z axis) 8 kg/4 kg (maximum speed cannot be maximum load)		
移动速度 rate of travel	(X/Y轴)0.1-300mm/s(Z轴)0.1-200mm/s		
重复精度 repeatability	≤0.01mm		
存储内存 Storage memory	64G超大容量高速固态硬盘文件存储器 (可定制120G) 64G ultra-large capacity high-speed fixed disk file storage (customizable 120G)		
驱动方式 type of drive	高精度马达系统 (可选配伺服系统) High precision motor system (optional servo system)		
操作模式 operator schema	工业控制电脑 Industrial control computer		
传动方式 Transmission mode	精密丝杠模组 Precision screw module		
视觉定位系统 Visual positioning system	标配高像素工业相机 High-pixel industrial cameras are standard.		
控制方式 Control mode	基于MC专业控制器 Professional controller based on MC		
编程模式 Programming mode	键鼠+显示器 Keymouse+display		
视觉分辨率 Visual resolution	0.01*0.01mm/Pixel(可调)		
光源 light source	LED环形, 同轴光源 (通讯协议自动调光) LED ring, coaxial light source (communication protocol automatic dimming)		
识别范围 Recognition range	14*14mm		
输入电源 Working environment humidity	AC 110V/220V(内部切换) 50-60HZ		
工作环境温度湿度 Programming mode	5-40°C/20-90%		
外型尺寸 External dimension	L485*W395*H561	L585*W495*H561	
本体重量 Body weight	约45kg	约55kg	

双Y四轴伺服视觉激光焊接机

Double Y Four-axis Servo Vision Laser Welding Machine

型号：NS.LS.940HE-Y

产品特点

Features

- 1.视觉识别、压力实时反馈、能量实时监控、能量异常报警；
 - 2.精密破锡送丝机、激光器、和控制系统集成一体，能实现自动送锡丝；
 - 3.激光通过激光器光纤传输聚焦后，照射工件表面及锡丝上进行恒温熔锡形成稳定可靠的焊锡效果
 - 4.可实现自动送锡丝、激光熔锡焊接的整个工艺过程；
1. Visual recognition, real-time pressure feedback, real-time energy monitoring and abnormal energy alarm;
 2. The precise tin breaking wire feeder, laser and control system are integrated to realize automatic tin wire feeding;
 3. After the laser is transmitted and focused through the laser fiber, it irradiates the of workpiece and the tin wire for constant-temperature tin melting to form reliable effect.
 4. The whole process of automatic tin wire feeding and lase melting welding realized;



产品参数

Product parameters

产品型号 product model	NS.LS.940HE-Y
运动范围 Range of motion	400*400*100mm
激光波长 Laser wavelength	915nm
制冷方式 Refrigeration	全风冷 All-air cooling
锡丝规格 Tin wire specification	0.3-1.2mm
运动控制 motor control	PLC+PC
定位CCD精度 Positioning CCD accuracy	±0.01mm
重复精度 repeatability	±0.04mm (X/Y) ; ±0.02mm (Z)
工位数量 Welding range	双工位 Duplex position
焊接范围 Welding range	200*200mm
焊接效率 Welding efficiency	About 1S
焊接可视 Welding visualization	焊接同轴监控 Coaxial welding monitoring
输入电源 Input power supply	AC110V/220/50-60Hz
功率 power	100W
外形尺寸 power	800 (L) *640 (W)*950(H) mm
本体重量 Body weight	260kg

落地式双Y视觉激光焊接机

Floor Type Double Y Vision Laser Welding Machine

型号: NS.JGH.5660HE-OL

产品特点

Features

1. 操作简单便利、高速精确。(比同类产品精度高出1倍);
 2. 自动视觉定位, 焊接位置, 点锡膏位置精度极高;
 3. 设备可预存多组加热曲线参数, 以适应不同的焊接对象, 可精确, 快速调整加热曲线;
 4. 非接触焊接, 隔绝静电对元器件的损害, 无焊接过程接触应力, 振动;
 5. 加热时间短, 对元器件热影响小, 最小化热损坏和热变形;
 6. 焊接烟尘少, 无需辅助空气净化设备;
1. Simple and convenient operation, high speed and accuracy. (1 times higher than similar products);
 2. Automatic visual positioning, welding position and soldering paste position high accuracy;
 3. The equipment can pre-store multiple groups of parameters different welding objects and adjust the heating curve accurately and quickly;
 4. Non-contact welding, isolating the damage components, without and vibration welding;
 5. The heating time is short, influence on components and minimizes thermal deformation;
 6. Less welding smoke and dust, no need for auxiliary air purification equipment;



产品参数

Product parameters

产品型号 product model	NS.JGH.5660HE-OL
运动范围 Range of motion	(X/Y1、Y2 /Z轴) 500/600/600/150mm
最大负载 maximum load	(Y/Z轴) 5Kg/3Kg
移动速度 rate of travel	0.1-500/300mm/s
重复精度 repeatability	0.01mm
存储内存 Storage memory	64G/120G
驱动方式系统 Driving mode system	精密闭环马达 Precision closed-loop motor
操作模式 operator schema	工业控制电脑 Industrial control computer
视觉定位系统 Visual positioning system	标配高像素工业相机 High-pixel industrial cameras are standard.
光源系统 Light source system	LED环形, 同轴光源 (通讯协议自动调光) LED ring, coaxial light source (communication protocol automatic dimming)
传动方式 Transmission mode	精密丝杆模组 Precision screw module
编辑模式 Edit mode	键鼠 / PC Keymouse/PC
I/O讯号 I/O signal	可支持16Inputs /24Outputs
扩展接口 expansion interface	支持LAN接口MES扩展 Support MES extension of LAN interface.
激光输出功率 (系统) Laser output power (system)	标配100W 选配30W/50W/200W 100W as standard and 30w/50w/200w as optional.
最小光斑直径 (系统) Minimum spot diameter (system)	标配 0.4mm 0.4mm as standard
输入电源 Input power supply	AC 110V/220V(内部切换) 50~60Hz
功率 (W) Power (w)	850W
工作环境(温度/湿度) environment (temperature/humidity)	5 - 40 °C/20 - 90%
外型尺寸(WxDxH mm) Overall dimension (WxDxH mm)	905*903*1650mm
本体重量(kg) Body weight (kg)	约85kg

自动视觉微点焊机

Automatic Vision Micro Spot Welding Machine

型号: AUTO.D-DH-920GE

产品特点

Features

1. 桌面式，移动方便，视觉识别定位；
 2. 专用焊接软件，操作简单，功能强大，新手2小时可熟练可节省50%人力；
 3. 可拓展性强，超高性价比；
1. Desktop type, easy to move, visual identification and positioning;
 2. Special welding software, simple operation and powerful function, which can save 50% manpower for novices to be skilled for 2 hours;
 3. Strong expandability and high cost performance;



产品参数

Product parameters

产品名称 product name	自动视觉点焊机--单头版 Automatic visual spot welding machine-single front page	自动视觉点焊机--双头版 Automatic visual spot welding machine-double front page
产品型号 product model	NS.AUTO.D-DH.920GE	NS.AUTO.D-DH.920GE -Y
运动范围 Range of motion	X450: Y:60 Z: 110	X:900 Y:100 Z: 150
最大负载 maximum load	2.5KG	2.5KG
移动速度 rate of travel	300mm/s	300mm/s
分解能力 resolution capability	0.01MM	0.01MM
重复精度 repeatability	±0.05	±0.05
程序存储数量 Program storage quantity	64G/120G	64G/120G
显示方式 display mode	显示器 indicator	显示器 indicator
编辑模式 Programming mode	工控机 Industrial Personal Computer	工控机 Industrial Personal Computer
马达系统 Transmission mode	精密步进马达 Precision stepping motor	精密步进马达 Precision stepping motor
传动方式 Transmission mode	同步带 Synchronous belt	同步带 Synchronous belt
输入电源 Working environment humidity	AC220V 50Hz	AC220V 50Hz
额定功率 rated power	1000w	1500w
焊接范围 Welding range	200*50	200*50
外形尺寸 outline dimension	L700*W440*H350	L1200*W855*H580
本体重量 VBody weight	30kg	60kg

自动视觉加锡机

Automatic visual tinning machine

型号: AUTO.D-SR.920GE-2Z

产品特点

Features

1. 桌面式, 移动方便, 视觉识别定位;
 2. 专用焊接软件, 操作简单, 功能强大, 新手2小时可熟练可节省50%人力;
 3. 可拓展性强, 超高性价比;
1. Desktop type, easy to move, visual identification and positioning;
 2. Special welding software, simple operation and powerful function, which can save 50% manpower for novices to be skilled for 2 hours;
 3. Strong expandability and high cost performance;



产品参数

Product parameters

产品名称 product name	自动视觉加锡机--单头版 Automatic visual spot welding machine-single front page	自动视觉加锡机--双头版 Automatic visual spot welding machine-double front page
产品型号 product model	NS.AUTO.D-DH.920GE	NS.AUTO.D-DH.920GE -Y
运动范围 Range of motion	X450: Y:60 Z: 110	X:900 Y:100 Z: 150
最大负载 maximum load	2.5KG	2.5KG
移动速度 rate of travel	300mm/s	300mm/s
分解能力 resolution capability	0.01MM	0.01MM
重复精度 repeatability	±0.05	±0.05
程序存储数量 Program storage quantity	64G/120G	64G/120G
显示方式 display mode	显示器 indicator	显示器 indicator
编辑模式 Programming mode	工控机 Industrial Personal Computer	工控机 Industrial Personal Computer
马达系统 Transmission mode	精密步进马达 Precision stepping motor	精密步进马达 Precision stepping motor
传动方式 Transmission mode	同步带 Synchronous belt	同步带 Synchronous belt
输入电源 Working environment humidity	AC220V 50Hz	AC220V 50Hz
额定功率 rated power	1000w	1500w
焊接范围 Welding range	200*50	200*50
外形尺寸 outline dimension	L700*W440*H350	L1200*W855*H580
本体重量 VBody weight	30kg	60kg

四轴焊锡机--烙铁旋转式

Four-axis Soldering Robot-Soldering Iron Rotary

型号: NS.SR.331/441R

产品特点

Features

1. 灵活多样焊锡方式，具有点焊、拖焊(拉焊)等功能;
 2. 设备具有自动清洗功能，一定程度上稳定了焊锡加工;
 3. 升温回温速度快，焊锡品质有保障;
1. Flexible and diverse soldering methods, with spot welding, drag welding (pull welding) and other functions;
 2. The equipment has automatic cleaning function, which stabilizes the certain extent;
 3. The temperature rise and return speed is fast, and the solder quality is guaranteed;



可搭配

Can be matched

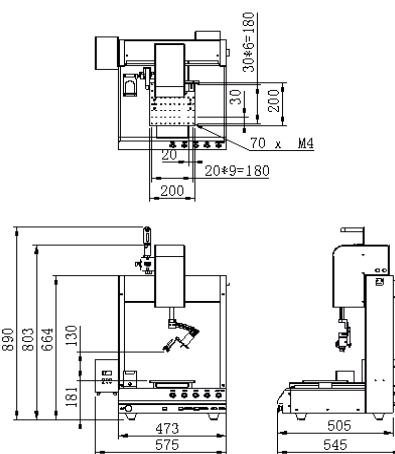

最大可加工产品范围: 280*260mm

产品参数

Product parameters

产品型号 product model	NS.SP.331R/441R	NS.SP.441R
运动范围 Range of motion	300X*300Y*80Zmm*360°R	400X*400Y*80Zmm*360°R
最大负载 maximum load	8kg/4kg	
移动速度 rate of travel	(X/Y) 轴0.1-500mm/s (Z) 轴0.1-300mm/s	
重复精度 repeatability	±0.01mm	
存储内存 Storage memory	超大容量高速文件储存器，可储存文件999个、每个56000点 (可支持U盘COPY) Super-capacity high-speed file storage, which can store 999 files with 56,000 points each (supporting U disk COPY).	
驱动方式 type of drive	精密步进电机 (选配伺服) Precision stepping motor (optional servo)	
锡线线径 Tin wire diameter	Ø0.4~Ø1.2mm	
温控功率 Temperature control power	150W (可选配320W)	
I/O讯号	4Inputs	
输入电源 Working environment humidity	AC110V/220V/50-60HZ 功率: 400W	
工作环境温度湿度 operating ambient temperature	5-40°C/20-90%	
设备功率 Equipment power	400W	
外型尺寸 outline dimension	L575*W545*H890MM	L675*W645*H890MM
本体重量 VBody weight	40kg	45kg

双Y五轴焊锡机--烙铁旋转式

Double Y Five-axis Soldering Machine--Soldering Iron Rotary

型号: NS.SR.531R-Y

产品特点

Features

- 1.精密温度控制器，温差补偿快，
 - 2.可拓展性强，超高性价比；
 - 3.高精度送锡机构，不堵锡，带破锡功能；
 - 4.可带旋转焊锡功能，支持点焊拖焊；
1. precise temperature controller, fast temperature difference compensation,
 2. strong expansibility and super high price comparison;
 3. High-precision tin feeding mechanism, which does not t function of breaking tin;
 4. It can have the function of solder, and support spot welding and dragwelding;

可搭配

Can be matched



送锡器
Tin feeder



无铅焊台
Lead-free table



金属手柄
Metal handle



手柄夹具
Handle clamp



烟雾净化器
Smoke purifier



锡渣清洗盒
Tin slag cleaning box



烙铁咀
Rongtiezui

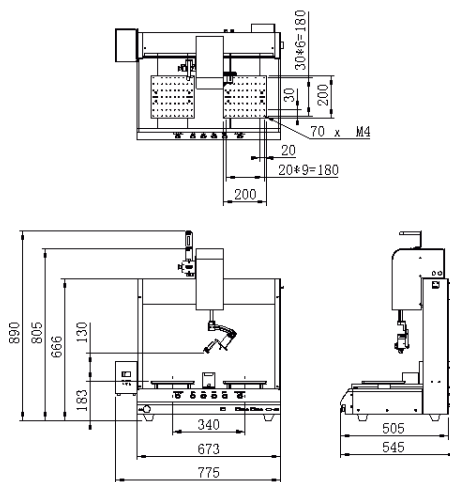

最大可加工产品范围: 220*280mm (双Y)

产品参数

Product parameters

产品型号 product model	NS.SR.531R-Y
运动范围 Range of motion	500X*300Y1*300Y2*80Zmm*360°R
最大负载 maximum load	8kg/4kg
移动速度 rate of travel	(X/Y) 轴0.1-500mm/s (Z) 轴0.1-300mm/s
重复精度 repeatability	±0.01mm
存储内存 Storage memory	超大容量高速文件存储器，可储存文件999个、每个56000点（可支持U盘COPY） Super-capacity high-speed file storage, which can store 999 files with 56,000 points each (supporting U disk COPY).
驱动方式 type of drive	精密步进电机（选配伺服） Precision stepping motor (optional servo)
锡线线径 Tin wire diameter	Ø0.4~Ø1.6mm
温控功率 Temperature control power	150W（可选配320W）
I/O讯号	4Inputs
输入电源 Working environment humidity	AC110V/220V/50-60HZ 功率：400W
工作环境温度湿度 operating ambient temperature	5-40°C/20-90%
设备功率 Equipment power	400W
外型尺寸 outline dimension	L720*W570*H725MM
本体重量 VBody weight	50kg

双Y双平台自动焊锡机

Double platform automatic soldering machine

型号: NS.SR.5331Y

产品特点

Features

1. 灵活多样焊锡方式，具有点焊、拖焊(拉焊)等功能;
 2. 设备具有自动清洗功能，一定程度上稳定了焊锡加工;
 3. 升温回温速度快，焊锡品质有保障;
1. Flexible and diverse soldering methods, with spot welding, drag welding (pull welding) and other functions;
 2. The equipment has automatic cleaning function, which stabilizes the soldering process to a certain extent;
 3. The temperature rise and return speed is fast, and the solder quality is guaranteed;



可搭配

Can be matched



送锡器
Tin feeder



无铅焊台
Lead-free table



金属手柄
Metal handle



手柄夹具
Handle clamp



烟雾净化器
Smoke purifier



锡渣清洗盒
Tin slag cleaning box



烙铁咀
Rongtiezui

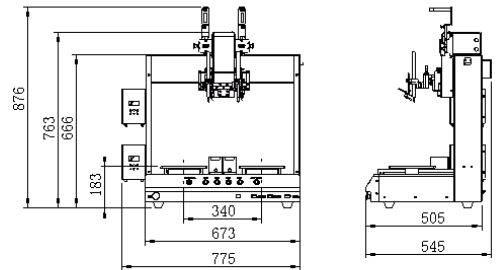
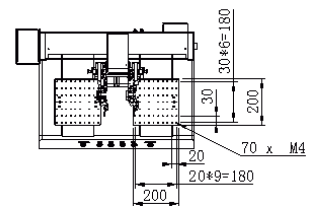

最大可加工产品范围: 220*280mm(双Y)

产品参数

Product parameters

产品型号 product model	NS.SR.5331-Y
运动范围 Range of motion	500X*300Y1*300Y2*80Zmm*360°R
最大负载 maximum load	8kg/4kg
移动速度 rate of travel	(X/Y) 轴0.1-500mm/s (Z) 轴0.1-300mm/s
重复精度 repeatability	±0.01mm
存储内存 Storage memory	超大容量高速文件储存器，可储存文件999个、每个56000点（可支持U盘COPY） Super-capacity high-speed file storage, which can store 999 files with 56,000 points each (supporting U disk COPY).
驱动方式 type of drive	精密步进电机（选配伺服） Precision stepping motor (optional servo)
锡线线径 Tin wire diameter	Ø0.4~Ø1.6mm
温控功率 Temperature control power	150W（可选配320W）
I/O讯号	4Inputs
输入电源 Working environment humidity	AC110V/220V/50-60HZ 功率：400W
工作环境温度湿度 operating ambient temperature	5-40°C/20-90%
设备功率 Equipment power	400W
外型尺寸 outline dimension	L775*W545*H890MM
本体重量 VBody weight	50kg

双Y双Z八轴焊锡机

Double Y double Z eight axis soldering machine

型号: NS.SR.531R-YZ

产品特点

Features

- 1.精密温度控制器，温差补偿快；
 - 2.可拓展性强，超高性价比；
 - 3.高精度送锡机构，不堵锡，带破锡功能；
 - 4.可带旋转焊锡功能，支持点焊拖焊；
1. Precise temperature controller, quick temperature difference compensation;
 2. Strong expandability and super-high price comparison;
 3. High-precision tin feeding mechanism, which does not block tin and has the function of breaking tin;
 4. It can have the function of rotating solder and support spot welding drag welding;

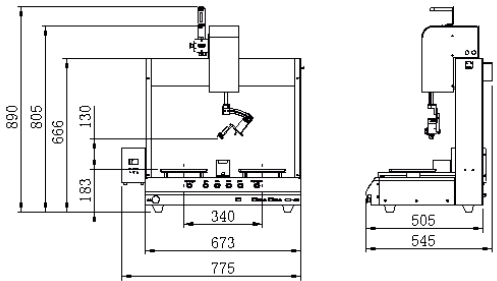
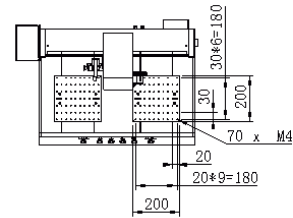

最大可加工产品范围: 220*280mm(双Y)

可搭配

Can be matched



送锡器
Tin feeder



无铅焊台
Lead-free table



金属手柄
Metal handle



手柄夹具
Handle clamp



烟雾净化器
Smoke purifier



锡渣清洗盒
Tin slag cleaning box



烙铁咀
Rongtiezui

产品参数

Product parameters

产品型号 product model	NS.SR.531R-YZ
运动范围 Range of motion	250X*300Y*80Zmm*360°R
最大负载 maximum load	8kg/4kg
移动速度 rate of travel	(X/Y) 轴0.1-500mm/s (Z) 轴0.1-300mm/s
重复精度 repeatability	±0.01mm
存储内存 Storage memory	超大容量高速文件存储器，可储存文件999个、每个56000点（可支持U盘COPY） Super-capacity high-speed file storage, which can store 999 files with 56,000 points each (supporting U disk COPY).
驱动方式 type of drive	精密步进电机（选配伺服） Precision stepping motor (optional servo)
锡线线径 Tin wire diameter	Ø0.4~Ø1.6mm
温控功率 Temperature control power	150W（可选配320W）
I/O信号	4Inputs
输入电源 Working environment humidity	AC110V/220V/50-60HZ 功率：400W
工作环境温度湿度 operating ambient temperature	5-40°C/20-90%
设备功率 Equipment power	500W
外型尺寸 outline dimension	L720*W570*H625MM
本体重量 VBody weight	50kg



微信扫码 与纳声互动
Wechat code scanning and nano-
-sound interaction



微信视频号
Wechat video number



东莞市纳声电子设备科技有限公司

DONGGUAN NASHENG ELECTRONIC EQUIPMENTTECHNOLOGYCO., LTD

Add: 东莞市松山湖高新技术产业开发区工业东路24号4栋

Add: Building 4, No.24 Gongye East Road, Songshan Lake High-tech Industrial Development Zone, Dongguan City

越南办事处 越南海防市

VIETNAM OFFICE

吉安办事处 吉安市吉安县

JI'AN OFFICE

常州办事处 江苏省常州市

CHANGZHOU OFFICE

TELEPHONE: ☎ 400-822-9298

<http://www.nashengcn.com>

2024~V1.2版本